

RECORD POWER
ESTABLISHED 1909®

Original Instruction Manual

BS10

10" Standard Bandsaw

Version 3.1

February 2014



To register this product please visit
www.recordpower.info

It is important to register your product as soon as possible in order to receive efficient after sales support and be entitled to the full **5 year guarantee**. Your statutory rights are not affected.
Please see back cover for contact details.



Always wear safety glasses when using woodworking equipment.



Always read the instructions provided before using woodworking equipment.

Important

For your safety read instructions carefully before assembling or using this product.

Save this manual for future reference.

Contents

- 1 Explanation of Symbols
 - 2 Health & Safety Guidance
 - 3 Additional Health & Safety Guidance for Bandsaws
 - 4 Record Power Guarantee
 - 5 Getting to Know the Bandsaw
 - 6 Specifications
 - 7 Assembly of the Optional Leg Stand
 - 8 Machine Assembly
 - 9 Machine Setting
 - 10 Bandsaw Blade Set Up
 - 11 Electrical Connection & Wiring Diagram
 - 12 Operation & Bandsawing Practice
 - 13 Dust Extraction
 - 14 Maintenance
 - 15 Parts List & Diagrams
- EU Declaration of Conformity



WARNING: This product is heavy and as a precaution it is advised that two people assemble the machine.

1. Explanation of Symbols

THE SYMBOLS AND THEIR MEANINGS SHOWN BELOW MAY BE USED THROUGHOUT THIS MANUAL. PLEASE ENSURE THAT YOU TAKE THE APPROPRIATE ACTION WHEREVER THE WARNINGS ARE USED.

Mandatory Instructions



Read and fully understand the instruction manual before attempting to use the machine.



Indicates an instruction that requires particular attention



Wear protective eyewear



Use respiratory protective equipment



Use hearing protection



Use suitable protective footwear



Use protective work gloves

Warning



Indicates a risk of severe personal injury or damage to the machine



Indicates a risk of severe personal injury from electrical shock



Risk of personal injury from lifting of heavy items



Indicates a risk of severe personal injury from airborne objects



Risk of fire

2. General Health & Safety Guidance

Ensure that you carefully read and fully understand the instructions in this manual before assembly, installation and use of this product. Keep these instructions in a safe place for future reference.

WARNING: for your own safety, do not attempt to operate this machine until it is completely assembled and installed according to these instructions.

WARNING: When using any machine, basic safety precautions should always be followed to reduce the risk of fire, electric shock and personal injury.

Safe Operation

1. Use Personal Protective Equipment (PPE)

- The operation of any machine can result in foreign objects being thrown into your eyes, which can result in severe eye damage. Protective eyewear or other suitable eye protection or face shield should be used at all times. Everyday spectacles only have impact resistant lenses. They are not protective eyewear and do not give additional lateral protection.
- Use respiratory protective equipment (dust mask etc.) if the machining operation creates dust. Exposure to high levels of dust created by machining hardwoods, softwoods and man made composite boards can result in serious health problems. Some imported hardwoods give off highly irritating dust, which can cause a burning sensation. The use of respiratory protective equipment should not be seen as an alternative to controlling the risk of exposure at source by using adequate dust extraction equipment.
- The use of ear plugs or ear defenders is recommended when the machine is in use, particularly if the noise level exceeds 85 dB.
- Wear suitable protective gloves when handling cutting tools or blades. Gloves should NOT be worn when using the machine as they can be caught in moving parts of the machine.
- Non-slip safety footwear is recommended when using the machine and handling large work pieces.

2. Dress appropriately

- Do not wear loose clothing, neckties or jewellery; they can be caught in moving parts of the machine.
- Roll up long sleeves above the elbow.
- Wear protective hair covering to contain long hair.

3. Safety warnings

- Find and read any warning labels on the machine.
- It is important that any labels bearing health and safety warnings are not removed, defaced or covered. Replacement labels can be obtained by contacting our Customer Service Department.

4. Familiarise yourself with the machine

- If you are not thoroughly familiar with the operation of this machine, obtain advice from your supervisor, instructor, or other qualified person or contact your retailer for information on training courses. Do not use this machine until adequate training has been undertaken.

5. Take care when moving or positioning the machine

- Some machines can be very heavy. Ensure the floor of the area in which the machine is to be used is capable of supporting the machine.
- The machine and its various components can be heavy. Always adopt a safe lifting technique and seek assistance when lifting heavy components. In some cases it may be necessary to use mechanical handling equipment to position the machine within the work area.

- Some machines have optional wheel kits available to allow them to be manoeuvred around the workshop as required. Care should be taken to install these according to the instructions provided.
- Due to the nature of the design of some machines the centre of gravity will be high making them unstable when moved. Extreme care should be taken when moving any machine.
- If transportation of the machine is required then all precautions relating to the installation and handling of the machine apply. In addition, ensure that any vehicles or manual handling equipment used for transportation are of adequate specification.

6. The machine should be level and stable at all times

- When using a leg stand or cabinet base that is designed to be fitted to the machine, always ensure that it is securely fastened to the machine using the fixings provided.
- If the machine is suitable to be used on a workbench, ensure that the workbench is well constructed and capable of withstanding the weight of the machine. The machine should always be securely fastened to the workbench with appropriate fixings.
- Where possible, floor standing machines should always be secured to the floor with fixings appropriate to the structure of the floor.
- The floor surface should be sound and level. All of the feet of the machine should make contact with the floor surface. If they do not, either re-locate the machine to a more suitable position or use packing shims between the feet and the floor surface to ensure the machine is stable.

7. Remove adjusting keys and wrenches

- Ensure that all adjusting wrenches and keys are removed before switching the machine 'ON'. There is a risk of severe personal injury or damage to the machine from airborne objects.

8. Before switching the machine 'ON'

- Clear the machine table of all objects (tools, scrap pieces etc.)
- Make sure there is no debris between the work piece and the table / work support.
- Ensure that the work piece is not pressed against, or touching the saw blade or cutting tool.
- Check all clamps, work holding devices and fences to ensure that they are secure and cannot move during machining operations.
- Plan the way that you will hold and feed the work piece for the entire machining operation.

9. Whilst machining

- Before starting work, watch the machine while it runs. If it makes an unfamiliar noise or vibrates excessively, switch the machine 'OFF' immediately and disconnect it from the power supply. Do not restart until finding and correcting the source of the problem.

10. Keep the work area clear

- Working clearances can be thought of as the distances between machines and obstacles that allow safe operation of every machine without limitation. Consider existing and anticipated machine needs, size of material to be processed through each machine and space for auxiliary stands and/or work tables. Also consider the relative position of each machine to one another for efficient material handling. Be sure to allow yourself sufficient room to safely operate your machines in any foreseeable operation.
- Cluttered work areas and benches create the risk of accidents. Keep benches clear and tidy away tools that are not in use.
- Ensure that the floor area is kept clean and clear of any dust and debris that may create trip or slip hazards.

2. General Health & Safety Guidance - cont.

11. Consider the work area environment

- Do not expose the machine to rain or damp conditions.
- Keep the work area well lit and ensure that there is artificial lighting available when there is insufficient natural light to effectively light the work area. Lighting should be bright enough to eliminate shadow and prevent eye strain.
- Do not use the machine in explosive environments eg. in the presence of flammable liquids, gases or dust.
- The presence of high levels of dust created by machining wood can present a risk of fire or explosion. Always use dust extraction equipment to minimise the risk.

12. Keep other persons away (and pets)

- The machine is designed to be used by one person only.
- Do not let persons, especially children, touch the machine or extension cable (if used) and keep visitors away from the work area.
- Never leave the machine running unattended. Turn the power supply off and do not leave the machine unattended until it comes to a complete stop.
- If the work area is to be left unattended, all machinery should be switched 'OFF' and isolated from the mains power supply.

13. Store machines safely when not in use

- When not in use, machines should be stored in a dry place, out of reach of children. Do not allow persons unfamiliar with these instructions or with the machine to operate it.

14. Do not overreach

- Choose a working position that allows your body to remain balanced and feed the work piece in to the machine without overreaching.
- Keep proper footing and balance at all times.

15. Electrical supply

- Electrical circuits should be dedicated to each machine or large enough to handle combined motor amp loads. Power outlets should be located near each machine so that power or extension cables are not obstructing high-traffic areas. Observe local electrical guidelines for proper installation of new lighting, power outlets, or circuits.
- The machine must be connected to an earthed power supply.
- The power supply must be equipped with a circuit breaker that provides short circuit, overload and earth leakage protection.
- The voltage of the machine must correspond to the voltage of the mains power supply.
- The mains plug fitted to the machine should always match the power outlet. Do not modify the plug in any way. If a replacement plug is required it should be fitted by a competent person and of the correct type and rating for the machine.
- If you are unsure about any electrical connections always consult a qualified electrician.

16. Avoid unintentional starting of the machine

- Most machines are fitted with a no-volt release (NVR) switch to prevent unintentional starting. In doubt always ensure the machine switch is in the 'OFF' position before connecting it to the power supply. This means the machine will not automatically start up after a power cut or switching on of the power supply, unless you first reset the start switch.

17. Outdoor use

- Your machine should not be used outdoors.

18. Extension cables

- Whenever possible, the use of extension cables is not recommended. If the use of an extension cable is unavoidable, then it should have a minimum core cross section of 2.5 mm² and limited to a maximum length of 3 metres.

- Extension cables should be routed away from the direct working area to prevent a trip hazard.

19. Guard against electric shock

- Avoid body contact with earthed or grounded surfaces such as pipes and radiators. There is an increased risk of electric shock if your body is earthed or grounded.

20. Always work within the machine's intended capacities

- Operator safety and machine performance are seriously adversely affected if attempts to make the machine perform beyond its limits are made.

21. Do not abuse the power cable

- Never pull the power cable to disconnect it from the power socket. Always use the plug.
- Keep the power cable away from heat, oil and sharp edges.
- Do not use the power cable for carrying or moving the machine.

22. Secure the work piece

- Ensure that the work piece is securely held before starting to machine it.
- When working within 300 mm of the machining area, always use a push stick to feed the work piece in to the blade or cutting tool. The push stick should have a minimum length of 400 mm. If the push stick becomes damaged, replace it immediately.
- Use extra supports (roller support stands etc.) for any work pieces large enough to tip when not held down to the table top.
- Do not use another person as a substitute for a table extension, or as additional support for a work piece that is longer or wider than the basic table, or to help feed, support, or pull the work piece.
- Do not attempt to machine more than one work piece at a time.
- When feeding the work piece towards the blade or cutting tool never position your hands in direct line of the cutting path. Avoid awkward operations and hand positions where a sudden slip could cause your hand or fingers to move into the machining area.

23. Stay alert

- Safety is a combination of operator common sense and alertness at all times when the machine is being used.
- Use all machines with extreme care and do not use the machine when you are tired or under the influence of drugs, alcohol or medication.

24. Use the correct tool for the job

- Do not use the machine for any purpose other than which it was designed.
- When selecting replacement cutting tools and blades, always ensure that they are designed to cut the material that you intend to use them for. If in any doubt seek further advice from the manufacturer.

25. Connect dust extraction equipment

- Always use dust extraction equipment. The dust extractor should be of suitable size and capacity for the machine that it is connected to and have a filtration level appropriate to the type of waste being collected. Refer to the relevant section of the manual for details of the specific dust extraction requirements for this machine.
- The dust extractor should be switched 'ON' before starting the machine that it is connected to. The dust extractor should be left running for 30 seconds after the last machining operation is complete in order to clear any residual waste from the machine.

26. Ensure that the machine is correctly guarded

- Never use the machine if any of the standard safety guards and equipment are removed or damaged.
- Some machines incorporate safety interlocks to prevent the machine from being used without the guards in place. Never attempt to bypass or modify the interlocks to allow the machine to be used without the

2. General Health & Safety Guidance - cont.

guards in place.

27. Maintain your machine with care

- This manual gives clear instructions on installation, set up and operation of the machine and also details any routine and preventative maintenance that should be performed periodically by the user.
- Remember always to switch off and unplug the machine from the power supply before carrying out any setting up or maintenance operations.
- Follow any instructions for the maintenance of accessories and consumables.
- Do not use compressed air to clean the machine. Always use a brush to dislodge dust in places that are awkward to reach and a dust extractor to collect the waste.
- Inspect electric cables periodically and, if damaged, have them replaced by an authorised service facility or qualified electrician.
- Inspect extension cables (if used) periodically and replace if damaged.

28. Keep cutting tools sharp and clean

- Correctly maintained cutting tools are easier to control and less likely to bind.
- Cutting tools and blades can become hot during use. Take extreme care when handling them and always allow them to cool before changing, adjusting or sharpening them.

29. Disconnect the machine from the power supply

- When not in use, before servicing, changing blades etc. always disconnect the machine from the power supply.

30. Check for damaged parts

- Before each use of the machine, it should be carefully checked to determine that it will operate properly and perform its intended function.
- Check for alignment of moving parts, binding of moving parts, breakage of parts and any other conditions that may affect the operation of the machine.
- A guard or other part that is damaged should be properly repaired or replaced by a qualified person unless otherwise indicated in this instruction manual.
- Do not use the machine if the switch does not turn the machine 'ON' and 'OFF'.
- Have defective switches replaced by a qualified person.

31. Warning!

- The use of any accessory or attachment, other than those recommended in this instruction manual, or recommended by our Company may present a risk of personal injury or damage to the machine and invalidation of the warranty.

32. Have your machine repaired by a qualified person

- This machine complies with the relevant safety rules and standards appropriate to its type when used in accordance with these instructions and with all of the standard safety guards and equipment in place. Only qualified persons using original spare parts should carry out repairs. Failure to do this may result in considerable danger to the user and invalidation of warranty.

33. Caution! Motor may become hot during use

- It is normal for motors on some machines to become hot to the touch during use. Avoid touching the motor directly when in use.

3. Additional Health & Safety Guidance for Bandsaws

Safe Operation

1. Familiarise yourself with the machine

- Machining operations using bandsaws have a history of serious accidents. Most result from contact with the moving blade while presenting material to the blade or moving it from the table. Other minor accidents can occur whilst setting, cleaning, adjusting or maintaining the machine.
- The machine is designed for cutting wood and composite board (plywood, MDF etc.). Certain plastics can also be cut using a suitable blade.

2. Before switching the machine 'ON'

- Ensure that the blade is correctly tensioned and aligned on the bandwheels and the blade guides are correctly adjusted.
- Ensure that the teeth of the blade are pointing downwards.
- Check the condition of the blade to ensure that no teeth are missing, damaged or deformed and the blade is not cracked or split. If any of these conditions apply, replace the blade immediately.
- Ensure that the saw blade type and width are suitable for the material to be cut.
- Check that the blade width is within the minimum and maximum permitted on the machine and that the thickness of the blade is suitable for the diameter of the wheel.
- Some machines have more than one cutting speed. For most wood cutting applications the faster of the speeds should be used.
- Check the condition of the table insert. Replace it immediately if it is damaged or showing signs of wear.

- Adjust the guard as close as possible to the work piece being cut.
- Check that access doors are fully closed and that the latches are secure.

3. Whilst machining

- Never apply sideways pressure to the blade as this may cause the blade to break.
- Care must be taken when cutting wood with knots, nails or cracks in it and / or dirt on it, as these can cause the blade to get stuck. If this happens, switch the machine 'OFF' immediately and follow the procedure detailed in the manual to remove the blade from the work piece.
- If cutting cylindrical timber use a suitable jig to prevent twisting of the work piece.

4. This machine falls under the scope of the 'Health & Safety at Work etc. Act 1974', and the 'Provision & Use of Work Equipment Regulations 1998'. In addition the elimination or control of risks from wood dust is included in the above regulations and the 'Control of Substances Hazardous to Health (COSHH) Regulations 2002'. We recommend that you study and follow these regulations.

Further guidance can be found in the 'Safety in the use of narrow bandsaws – Woodworking sheet No.31' and the 'Safe use of woodworking machinery' code of practice booklet (L114) published by Health & Safety Executive and available from their website www.hse.gov.uk.

4. Record Power Guarantee

"Products" means the Products sold by Record Power subject to these terms and conditions;

"Record Power" is Record Power Limited, whose company registration number is 4804158 and registered office address is Centenary House, 11 Midland Way, Barlborough Links, Chesterfield, Derbyshire S43 4XA and sells through a network of Authorised Dealers;

"Authorised Distributor" is the nominated importer for your region who will generally sell through a network of Authorised Dealers. Details of Authorised Distributors for specific countries can be found in the Product manual or at www.recordpower.info;

"Authorised Dealer" is a retailer or business authorised to sell Record Power Products to end users.

1 Guarantee

- 1.1 Record Power guarantees that for a period of 5 years from the date of purchase the components of qualifying Products (see clauses 1.2.1 to 1.2.9) will be free from defects caused by faulty construction or manufacture.
- 1.2 During this period Record Power, its Authorised Distributor or Authorised Dealer will repair or replace free of charge any parts which are proved to be faulty in accordance with paragraphs 1.1 above provided that:
 - 1.2.1 you follow the claims procedure set out in clause 2 below;
 - 1.2.2 Record Power, our Authorised Distributor or Authorised Dealer are given a reasonable opportunity after receiving notice of the claim to examine the Product;
 - 1.2.3 if asked to do so by Record Power, its Authorised Distributor or Authorised Dealer, you return the Product, at your own cost, to Record Power's premises or other approved premises such as those of the Authorised Distributor or supplying Authorised Dealer, for the examination to take place;
 - 1.2.4 the fault in question is not caused by industrial use, accidental damage, fair wear and tear, wilful damage, neglect, incorrect electrical connection, abnormal working conditions, failure to follow our instructions, misuse, or alteration or repair of the Product without our approval;
 - 1.2.5 the Product has been used in a domestic environment only;
 - 1.2.6 the fault does not relate to consumable Products such as blades, bearings, drive belts or other wearing parts which can reasonably be expected to wear at different rates depending on usage (for full details contact Record Power or your local Authorised Distributor);
 - 1.2.7 the Product has not been used for hire purposes, by you or by a previous owner;
 - 1.2.8 the Product has been purchased by you as the guarantee is not transferable from a private sale.
 - 1.2.9 where the Product has been purchased from a retailer, the 5 year guarantee is transferable and begins on the date of the first purchase of the Product and in the event of a claim under this guarantee proof of the original purchase date will be required to validate the warranty period.

2 Claims Procedure

- 2.1 In the first instance please contact the Authorised Dealer who supplied the Product to you. In our experience many initial problems with machines that are thought to be due to faulty parts are actually solved by correct setting up or adjustment of the machines. A good Authorised Dealer should be able to resolve the majority of these issues much more quickly than processing a claim under the guarantee.

- 2.2 Any damage to the Product resulting in a potential claim under the guarantee must be reported to the Authorised Dealer from which it was purchased within 48 hours of receipt.
- 2.3 If the Authorised Dealer who supplied the Product to you has been unable to satisfy your query, any claim made under this Guarantee should be made directly to Record Power or its Authorised Distributor (for details of the Authorised Distributor in your country please see your Product manual or check www.recordpower.info for details). The claim itself should be made in a letter setting out the date and place of purchase, and giving a brief explanation of the problem which has led to the claim. This letter should then be sent with proof of the purchase date (preferably a receipt) to Record Power or its Authorised Distributor. If you include a phone number or email address this will help to speed up your claim.
- 2.4 Please note that it is essential that the letter of claim reaches Record Power or its Authorised Distributor on the last day of this Guarantee at the latest. Late claims will not be considered.
- 3 **Limitation of Liability**
 - 3.1 We only supply Products for domestic and private use. You agree not to use the Product for any commercial, business or re-sale purposes and we have no liability to you for any loss of profit, loss of business, business interruption or loss of business opportunity.
 - 3.2 This Guarantee does not confer any rights other than those expressly set out above and does not cover any claims for consequential loss or damage. This Guarantee is offered as an extra benefit and does not affect your statutory rights as a consumer.
- 4 **Notice**

This Guarantee applies to all Products purchased from an Authorised Dealer of Record Power within the United Kingdom of Great Britain and Northern Ireland. Terms of Guarantee may vary in other countries – please check with the Authorised Distributor in your country (details of the Authorised Distributor for your country can be found in the manual or at www.recordpower.info).

5. Getting to Know the Bandsaw

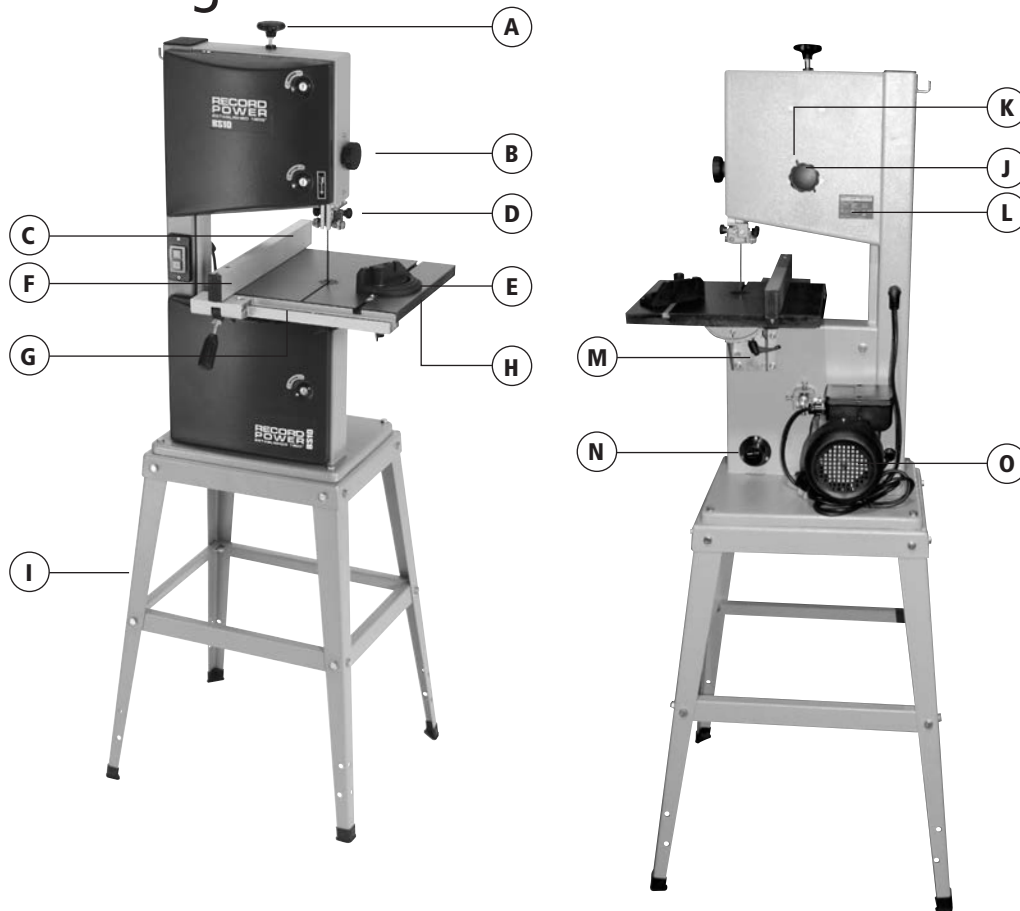

| Item | Description |
|------|-----------------------|
| A | Blade tensioning knob |
| B | Rise & fall knob |
| C | Blade |
| D | Upper blade guides |
| E | Mitre fence |

| Item | Description |
|------|--------------------|
| F | Rip fence |
| G | Rip fence rail |
| H | Table |
| I | Optional leg stand |
| J | Tracking knob |

| Item | Description |
|------|----------------------------|
| K | Tracking knob lock |
| L | Motor rating plate |
| M | Table tilting handle |
| N | 40 mm dust extraction port |
| O | Motor |

6. Specifications

| | |
|--|------------------------|
| Blade length: | 1712 mm |
| Blade width: | 6 - 10 mm |
| Max depth of cut: | 100 mm |
| Throat depth: | 245 mm |
| Table size: | 340 x 335 mm |
| Max width blade to rip fence: | 135 mm |
| Table height (from floor without leg stand): | 379 mm |
| Table height (from floor with leg stand): | 1057 mm |
| Extraction port: | 40 mm |
| Motor power: | 230 V / 50 Hz / 370 W |
| Weight: | 35 kg |
| Size (without stand): | H887 x W528 x D387 mm |
| Size (with stand): | H1565 x W630 x D458 mm |
| Sound power level: | <85 dBA |
| Sound pressure level: | <85 dBA |

7. Assembly of the Optional Leg Stand

Tools Required For Assembly & Maintenance

- 3 mm hex wrench (included with the machine)
- 5 mm hex wrench (not supplied)
- 10 - 13 mm combination wrench (included with the machine)



CAUTION! The machine is heavy. Additional help or a suitable lifting device or support will be required for lifting the machine onto the stand.

The stand comes as a self assembly unit:

- A** Upper frame
- B** Long mid brace supports x 2
- C** Short mid brace supports x 2
- D** Legs x 4
- E** Rubber feet x 4
- F** Long fixing bolts and nuts x 4
- G** Short fixing bolts, nuts and washers x 16
- H** Washers x 40

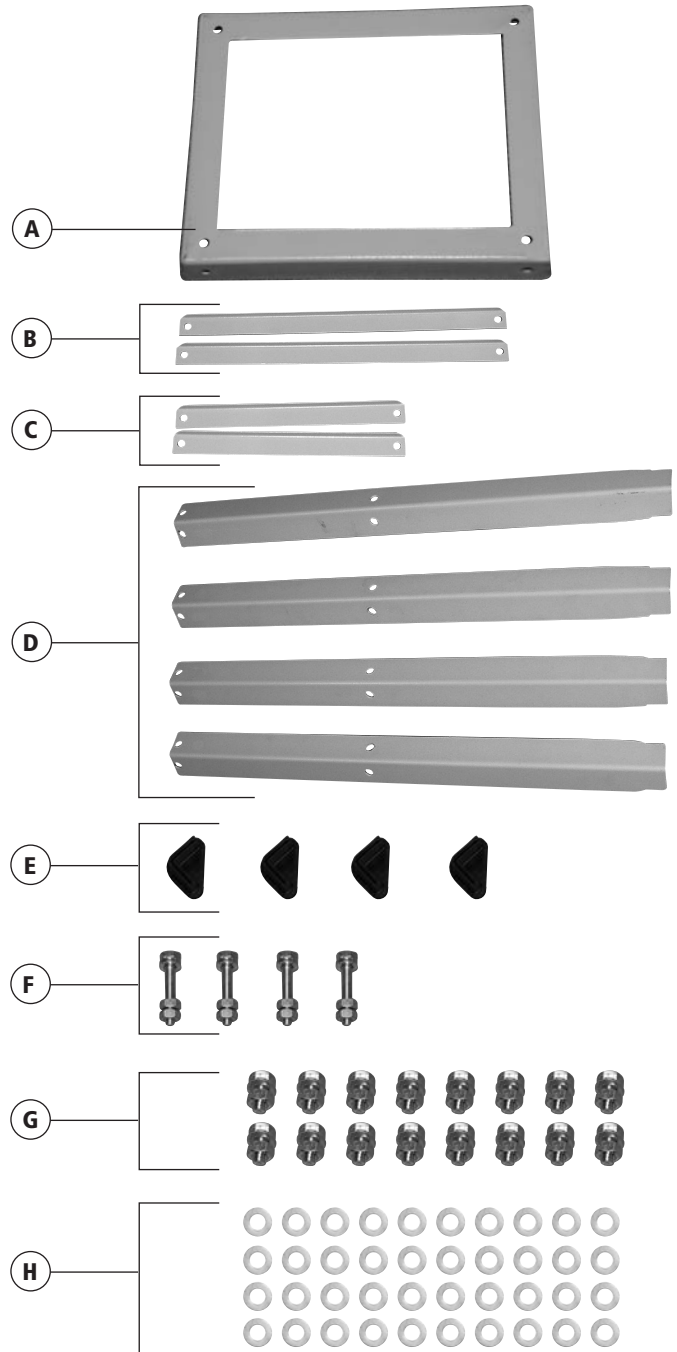

7. Assembly of the Optional Leg Stand - Cont.



Note:

When assembling the legstand **do not** fully tighten the nuts and bolts until the assembly is complete.

Stand Assembly

1. Locate the four legs (D) and secure them to the upper frame (A) using the nuts, bolts and washers supplied. Ensure that the tops of the legs are located on the inside of the top frame, **Fig 7.1**.
2. The locating holes a third of the way down each leg are for securing the long mid brace supports (B). Fix the long mid brace supports to the frame using the short nuts, bolts and washers (G), **Fig 7.2**.
3. Finally, fit the two short mid brace support (C) to the shorter sides of the stand, **Fig 7.3**.

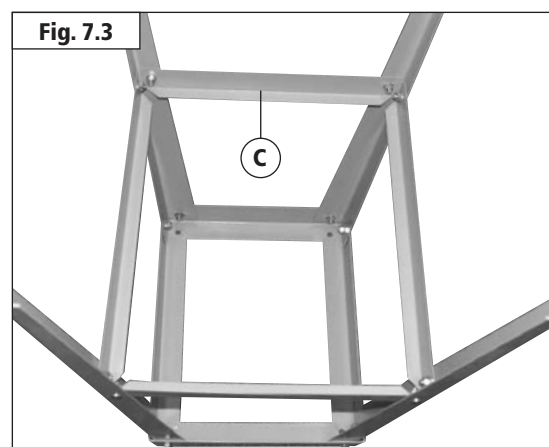
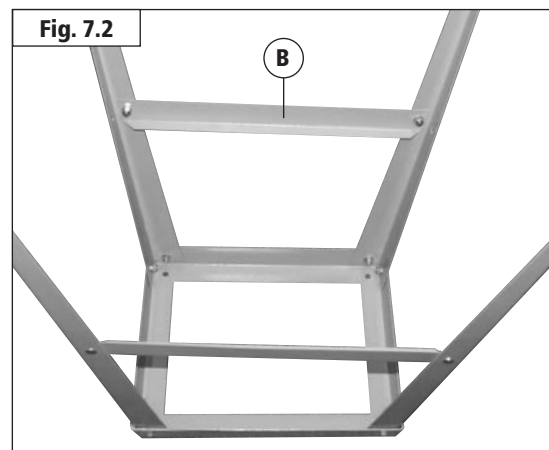
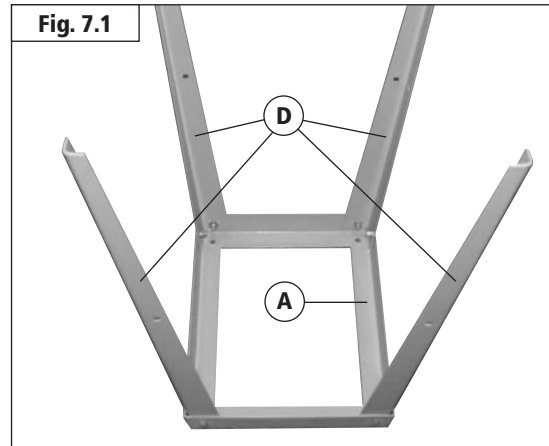

7. Assembly of the Optional Leg Stand - Cont.

4. Slide the rubber feet (E) onto the bottom of the bandsaw legs (D) and position the frame upright. Once the frame is upright all fixings should be fully tightened, see **Fig 7.4**.

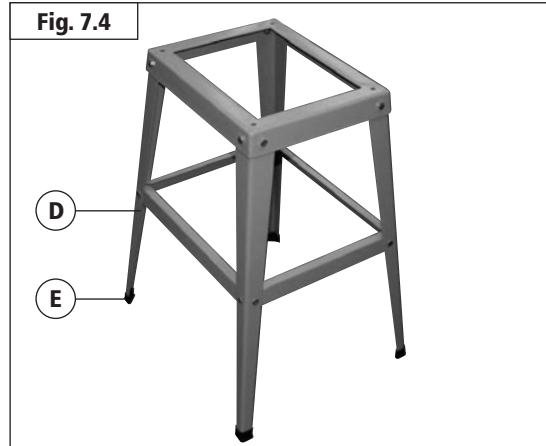

Fitting the Bandsaw to the Stand



CAUTION! The machine is heavy. Additional help or a suitable lifting device or support will be required for lifting the machine onto the stand.

1. Lift the bandsaw over the stand and place the long fixing bolts (F) through the four location holes in the bandsaw base, **Fig 7.5**.
2. Secure the bandsaw to the stand with the remaining washers and nuts, **Fig 7.6**.



8. Machine Assembly

Components Included and Unpacking

The machine is supplied partly assembled. Prior to use, further assembly is required.

When unpacking the machine the following components are included for the initial assembly.

- A** BS10 Bandsaw
- B** Table
- C** Fence
- D** Fence rail
- E** Mitre fence
- F** Push stick
- G** M6 x 15 mm hex head screw
- H** Serrated washers x 4
- I** Wing bolts x 4
- J** Washers x 4
- K** 3 mm Hex key
- L** M6 x 30 mm hex bolt
- M** M6 nut
- N** 10 and 13 mm open ended wrench
- O** M6 nut and push stick holder

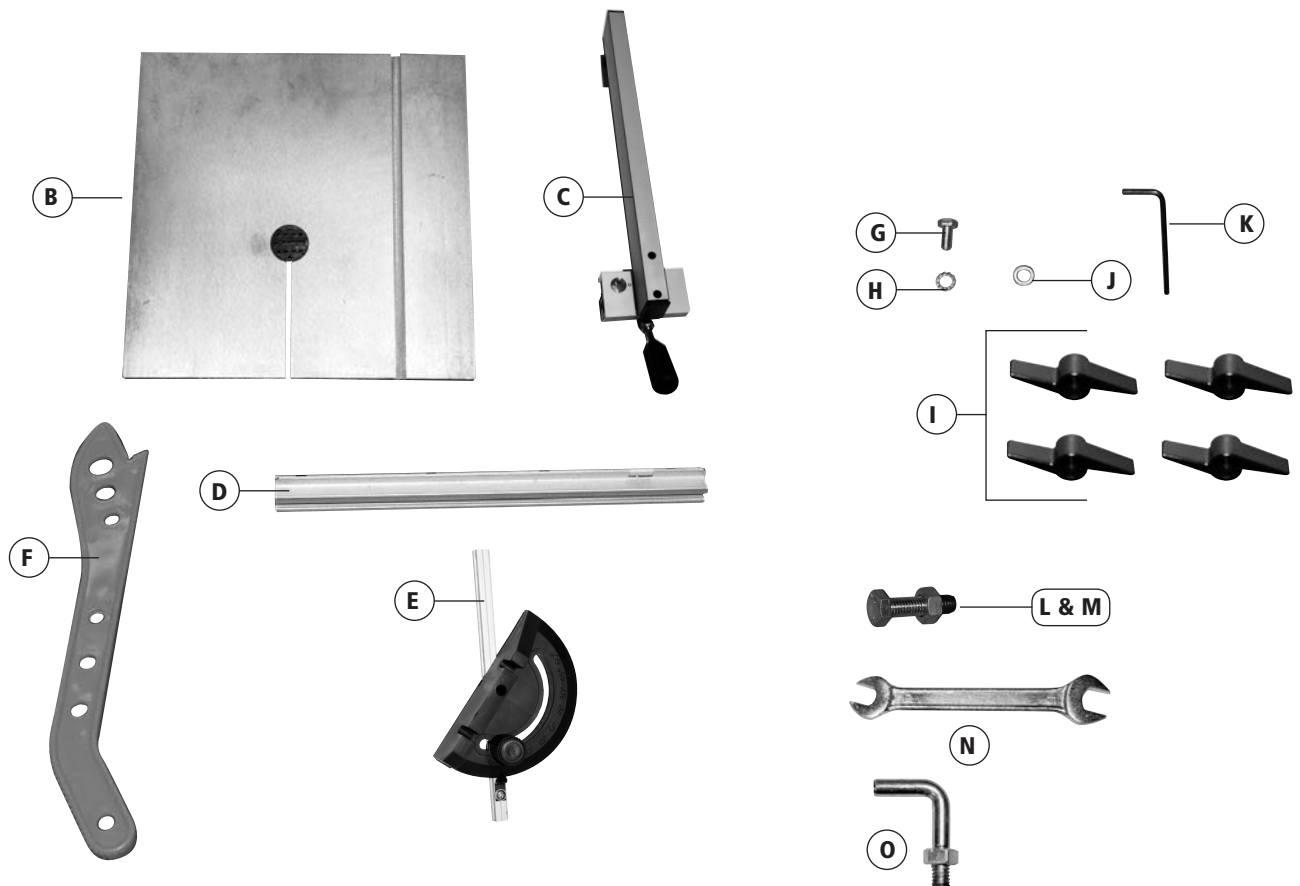

8. Machine Assembly - Cont.

After removing the machine it is advisable to make an initial setting to the lower blade guides. Open the lower door, using a flat blade screwdriver to undo the door locks and slacken the two blade guide locking knobs (Fig. 8.1, A), then position the guides to within 0.5 mm of the blade. Adjust the rear thrust guide by loosening the locking knob (Fig. 8.1, B) so that it is just clear of the back of the blade.

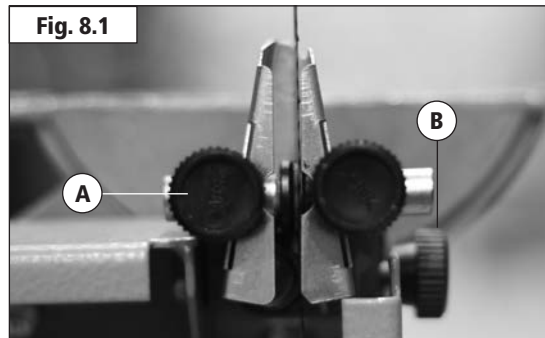

Fitting the table

First, turn the table upside down and fit the M6 x 30 mm hex head screw and M6 nut (Fig 8.2, A) in the threaded hole in the underside of the table (Fig 8.2, B). This acts as the table stop at 90° and will need to be adjusted once the table is fitted (described later in this section). Position the table on the trunnion of the machine, aligning the holes in the trunnion with the fixing holes in the underside of the table (Fig 8.3). Secure with the 4 M6 x 15 mm hex head screws and 4 serrated washers supplied.

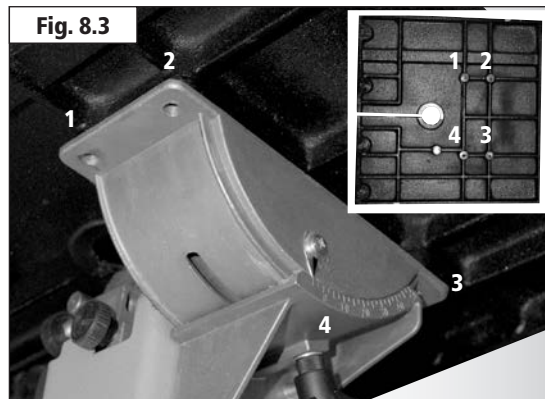
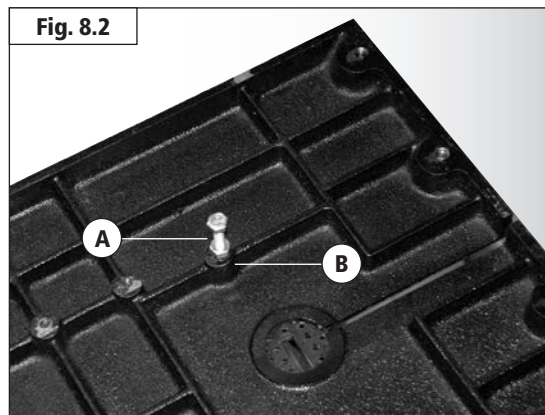

Fitting the Fence Rail

1. Take the four wing nuts and washers (Fig. 8.4, A) and fit them into the threaded holes on the underside of the table. But do not fully tighten.
2. Slide the fence rail (Fig. 8.4, B) into the gap left between the table and the wing bolt (Fig. 8.4, A) then tighten the wing bolt to secure the fence rail.

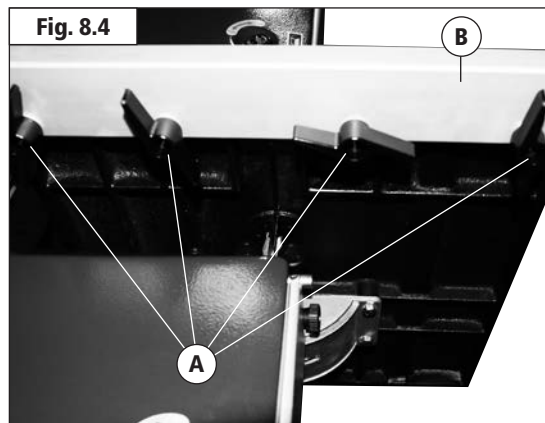

8. Machine Assembly - Cont.

Fitting the Rip Fence

1. Slide the rip fence (Fig. 8.5, A) assembly onto the fence rail (Fig. 8.5, B) ensuring that the retaining plate at the end of the rip fence is located under the rear edge of the table.
2. Pull down the locking lever (Fig. 8.5, C) to secure the position.



Tip:

When locking the rip fence it is advisable to place downward pressure on the top of the fence with one hand. This ensures that the fence registers correctly in the fence rail.

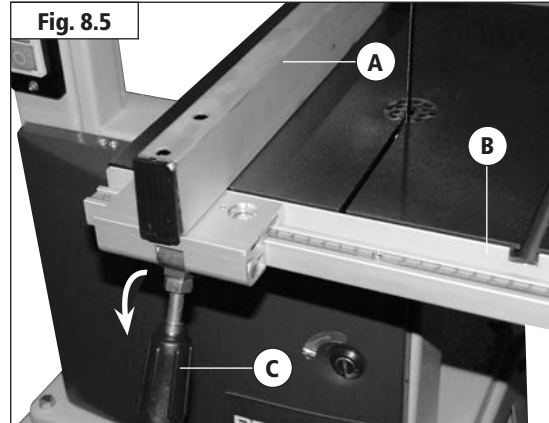

Checking the Drive Belt Tension

The tension of the drive belt must also be checked before operation of the machine. Please see the maintenance section of the manual for further details.

Fence Alignment 1

Adjustment can be made to the fence (Fig. 8.6, A) in relation to being parallel to the blade. This is done by slackening the four wing nuts on the fence rail (Fig. 8.6, B) and adjusting the rails position until the fence is parallel to the blade.



Note:

This adjustment must be made with the fence in a clamped position

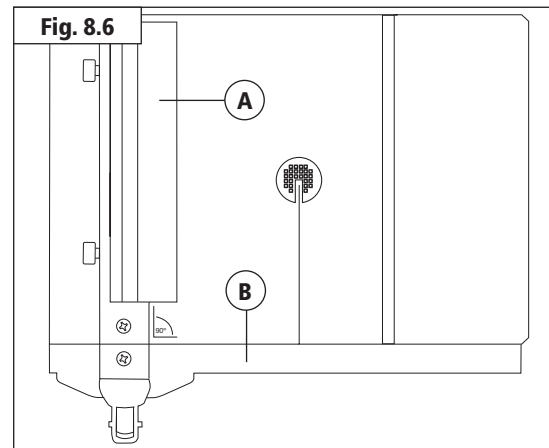

Fence Alignment 2

Check that the fence (Fig. 8.7, A) is 90° to the table (Fig. 8.7, B) using a suitable square, there is no need for adjustment as this area is factory set. However if settings have slipped during transit slight adjustment may be needed. The best way to adjust this is by adding extra washers or shims between the fence rail (Fig. 8.7, D) and the underside of the table where required.



Tip:

When an accurate cut is crucial it is good practice to check all settings before machining the workpiece and make a test cut with some scrap material.

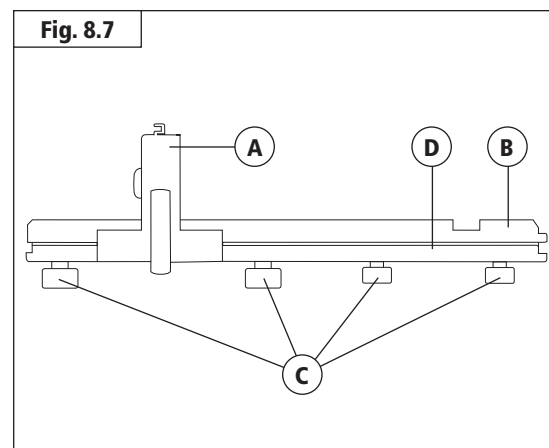

9. Machine Setting



CAUTION! Before carrying out any adjustments or maintenance ensure that the machine is isolated and disconnected from the electricity supply.

Tilting the Table

The tilt mechanism will be used when squaring the table to the blade. Tilt the table as follows:

1. Loosen the lock handle (Fig. 9.1, A) on the table trunnion (Fig. 9.1, D).
2. Adjust the table (Fig. 9.1, B) by hand to desired angle.
3. Use the angle indicator scale (Fig. 9.1, C) on the trunnion bracket to find the desired angle.
4. Re-tighten the lock handle to secure the table.

Setting the Table Stop at 90° to the Blade

Tools Required - Small 90° square (Not supplied), 10 mm wrench. The table can be set at 90° to the Bandsaw Blade by adjusting the table stop screw (Fig. 9.3, G) underneath the table.

1. First offer the square (Fig. 9.2, E) up to the blade (Fig. 9.2, F) to give an indication of adjustment required.
2. Adjust the table until it is 90° to the blade. If the table stop screw (Fig. 9.3, G) position is too high it may be necessary to wind this down out of the way so 90° can be achieved.
3. Once the table is at 90° to the blade, tighten the lock handle to secure the table position.
4. Now set the table stop screw (Fig. 9.3, G), the table stop screw should be adjusted to meet the registration point on top of the lower band wheel housing to ensure that the table always returns to square after tilting. By first slackening the locking nut and then adjusting the hex screw the table stop screw can be set correctly. Re-tighten the locking nut to ensure that the setting is maintained.

Adjusting the Table Tilt Scale

Once the table is set at 90° to the bandsaw blade it may be necessary to adjust the angle pointer on the angle scale so any further angles are accurate. To do this use a flat blade screwdriver to loosen the pan head screw and adjust the pointer to 0°.

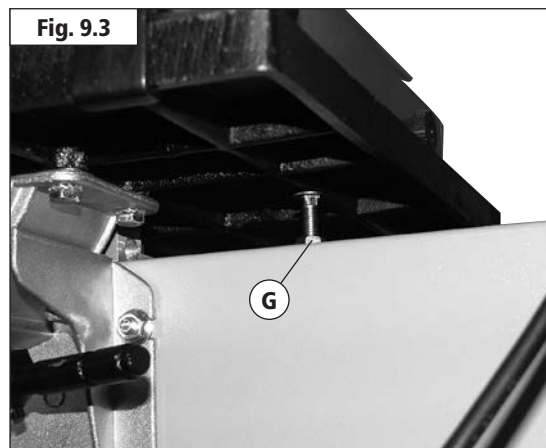
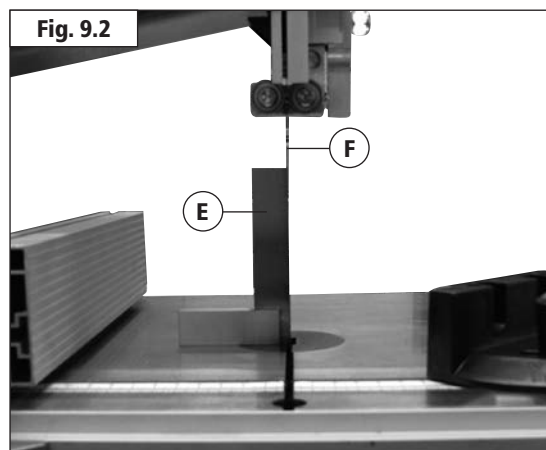
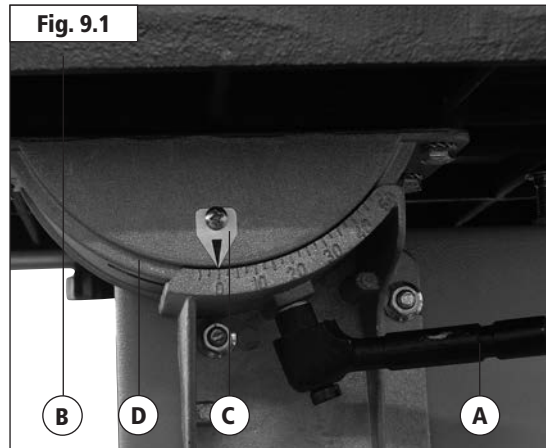

9. Machine Setting - Cont.



CAUTION! Before carrying out any adjustments or maintenance ensure that the machine is isolated and disconnected from the electricity supply.

Tensioning the Blade

The blade tensioning knob should be used to increase or decrease tension (**See Fig. 9.4**). The only truly accurate way to check a blade is with a tension meter. These are very expensive so most users may need another method. It is suggested to test the tension by the amount the blade will deflect sideways. First set the guides to 150 mm above the table, making sure the bandsaw is turned off. Push the blade sideways with a reasonable amount of pressure using a push stick. A correctly tensioned blade should not move more than 4 mm sideways, **Fig. 9.4 A**. If the blade is over-tightened, as in **Fig 9.4 B**, the blade could be damaged.

However perhaps the most tried and tested way of blade tensioning is simply: If the bandsaw is cutting accurately then the blade is tensioned correctly, if the blade tends to wander and an accurate cut cannot be achieved then the blade tension needs adjusting.

If the machine is to stand idle for a period it is good practice to slacken tension and re-tension when next using.

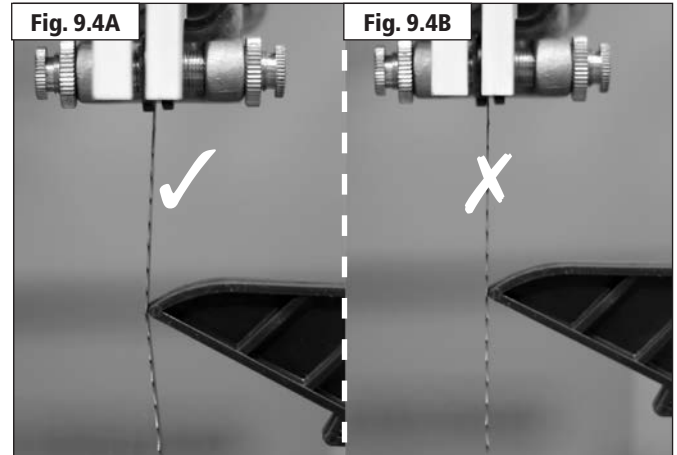

9. Machine Setting - Cont.

Tracking the Bandsaw Blade

Isolate the machine from the power supply by unplugging the mains plug. Set the tracking of the blade before setting the blade guides. Once the blade is tensioned, track the blade by turning the upper bandwheel by hand and adjusting the tracking knob (Fig. 9.5, B). When viewed from the rear of the machine, turning the tracking knob clockwise the blade will move towards the back of the bandwheel, by turning the tracking knob anti-clockwise the blade will move to the front of the bandwheel. The blade should run as close to the centre of the bandwheel as possible (Fig. 9.6). After the blade is tracked in the desired position on the bandwheel, rotate the wheel several more times by hand without any further adjustment ensuring that the blade remains in the same position. Once this has been achieved lock the tracking knob with the winged nut (Fig. 9.5, A).



Note:

It takes a few revolutions of the bandwheel for the effect of adjustment on the tracking knob to become apparent. To avoid over-adjusting, make small gradual adjustments on the tracking knob and revolve the bandwheel on a few times to check the effect before making further adjustments.

Fig. 9.5



Fig. 9.6

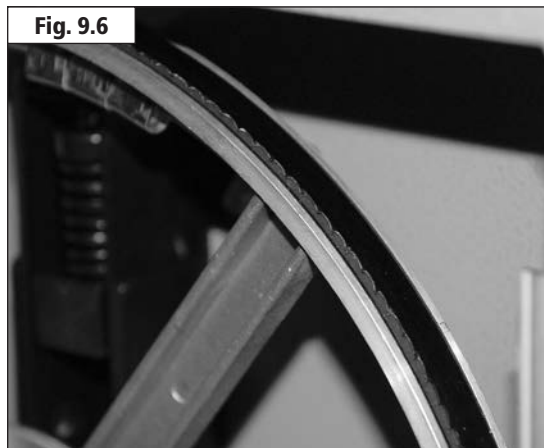

10. Bandsaw Blade Set Up



CAUTION! Before carrying out any adjustments or maintenance ensure that the machine is isolated and disconnected from the electricity supply.

Adjusting the Upper Guides

To adjust the upper blade guides, position the guide assembly relative to the blade by slackening off the guide carrier locking knob (Fig. 10.1, A) and moving the guide carrier until the side blade guides are just behind the gullets of the blade (Fig 10.2).

Set the blade guides relative to the blade by loosening the blade guide locking ring (Fig. 10.1, B) and moving the blade guide by screwing either in or out with the side guide adjuster (Fig. 10.1, C). The guides should be as close as possible to the blade but not touching it (Fig 10.3). Once correctly adjusted, tighten the blade guide locking ring. Set the rear thrust guide by loosening the rear thrust guide locking knob (Fig. 10.1, D) and moving the rear thrust guide until it is as close as possible to the blade without touching it (Fig 10.4).

Adjusting the Lower Guides

To adjust the lower blade guides, slacken off the lower guide assembly pivot bolt (Fig 10.5, A) at the rear of the guide assembly and move the assembly until the blade guides (Fig. 10.5, B) are just behind the gullets of the blade (Fig 10.2).

Set the blade guides relative to the blade by loosening the blade guide knob (Fig. 10.5, C) and moving the blade guides to be as close as possible to the blade without touching it (Fig 10.3).

Set the rear thrust guide by loosening the rear thrust guide knob (Fig 10.5 D) and positioning the rear thrust guide to be as close to the blade as possible without touching it (Fig 10.4).

Adjusting the Cutting Height

The cutting height must be adjusted so there is maximum guarding of the blade and optimum support to the blade is given.

To adjust the cutting height turn the rise and fall knob (Fig. 10.6, A) to raise or lower the guide post/upper blade guide assembly to the desired height.



Note:
The upper blade guides should provide approximately 5 mm clearance above the workpiece.

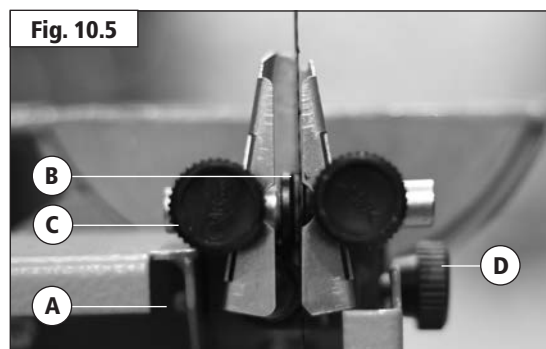
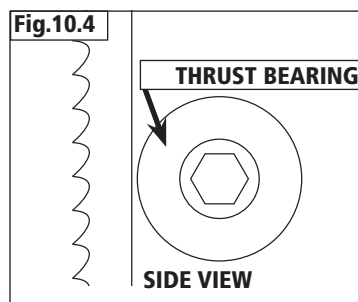
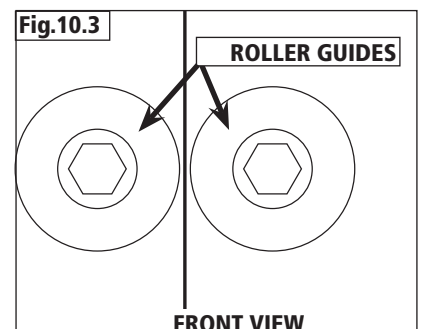
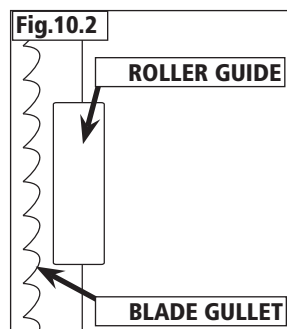
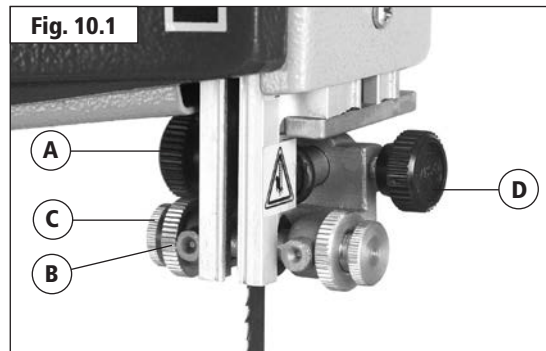

11. Electrical Connection & Wiring Diagram

Machines supplied for use in the UK are fitted with a 3 pin plug conforming to BS1363, fitted with a fuse conforming to BS1362 and appropriate to the current rating of the machine.

Machines supplied for use in other countries within the European Union are fitted with a 2 pin Schuko plug conforming to CEE 7/7.

Machines supplied for use in Australia & New Zealand are fitted with a 3 pin plug conforming to AS/NZS3112.

In all cases, if the original plug or connector has to be replaced for any reason, the wires within the mains power cable are colour coded as follows:

230 V (Single Phase)

Brown: Live (L)
Blue: Neutral (N)
Green and Yellow: Earth (E)

The wire coloured brown must always be connected to the terminal marked 'L' or coloured red.

The wire coloured blue must always be connected to the terminal marked 'N' or coloured black.

The wire coloured green and yellow must always be connected to the terminal marked 'E' or with the earth symbol:



or coloured green / green and yellow.

It is important that the machine is effectively earthed. Some machines will be clearly marked with the double insulated logo:



In this case there will not be an earth wire within the circuit.

In the case of the BS1363 plug for use in the UK, always ensure that it is fitted with a fuse conforming to BS1362 appropriate to the rating of the machine. If replacing the original fuse, always fit a fuse of equivalent rating to the original. Never fit a fuse of a higher rating than the original. Never modify the fuse or fuse holder to accept fuses of a different type or size.

Where the current rating of the machine exceeds 13 A at 230 V, or if the machine is designated for use on a 400 V 3 phase supply a connector conforming to BS4343 (CEE17 / IEC60309) will be used.

230 V machines will be fitted with a blue 3 pin connector. The wiring for this type of this connector will be the same as shown above.

400 V, 3 phase machines will be fitted with a red 4 or 5 pin connector. The wiring for this type of connector is as shown below:

400 V (3 phase)

Brown: Live (L1)
Black: Live (L2)
Grey: Live (L3)
Blue: Neutral (N)
Green and Yellow: Earth (E)

The wire coloured brown must always be connected to the terminal marked 'L1'.

The wire coloured black must always be fitted to the terminal marked 'L2'.

The wire coloured grey must always be connected to the terminal marked 'L3'.

The wire coloured blue must always be connected to the terminal marked 'N' or coloured black.

The wire coloured green and yellow must always be connected to the terminal marked 'E' or with the earth symbol

If in doubt about the connection of the electrical supply, always consult a qualified electrician.

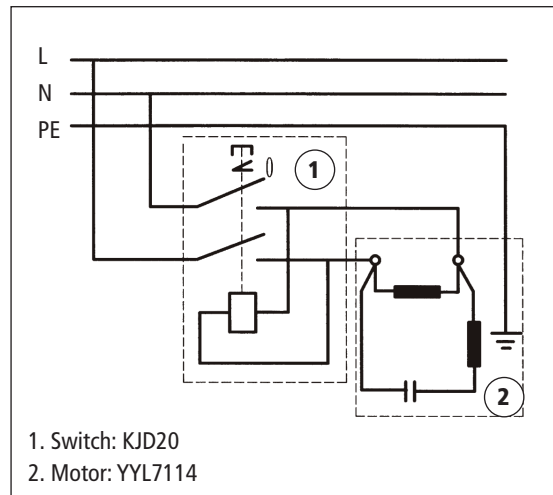

12. Operation & Bandsawing Practice

Basic Bandsawing Principles

- The blade cuts on a continuous down stroke.
- Slowly feed the workpiece towards the blade, using only light pressure whilst letting the blade do the cutting. Always use a push stick and take care.
- Firmly hold the workpiece and feed it towards the blade slowly, using the push stick and keeping your hands well away from the blade.
- For best results the blade must be sharp. Damaged or worn blades should always be replaced.
- Select the correct blade for the job, depending on the thickness of the wood and the cut to be made (see blade selection).
- For straight cutting use the rip fence supplied.
- When cutting shapes, follow the design marked out by pushing and turning the workpiece evenly. Do not attempt to turn the workpiece without pushing it, as this may cause the workpiece to get stuck, or the blade to bend.



CAUTION! Particular care should be taken towards the end of the cut as there will be a sudden decrease in resistance and care must be taken to stop hands from being thrown towards the blade. Always use a push stick.

Always ensure that your machine is properly maintained and clean. Before commencing work on an important project, it is advisable to familiarise yourself with the operation of the equipment by practising on low value or scrap materials.

Complicated Cutting

Very complicated cuts and small radius curves are the best accomplished with the aid of pre-drilled holes combined with a few tangential or radial cuts. This technique will achieve excellent results without putting undue tension on the blade and blade guide assembly.



WARNING! In circumstances such as cutting deep or wet timber, the work piece may close up behind the blade causing it to stall. In the event that the blade stalls whilst cutting, ease the work piece backwards slightly, to release feed pressure from the blade. Allow the blade to reach full speed before continuing to feed the work piece in to the blade. If the blade fails to move when feed pressure is released, immediately switch off the machine and disconnect the power supply before attempting to free the blade from the work piece.



WARNING! If any component of the machine fails whilst in use or if the blade should break whilst the machine is running, immediately switch off the machine and disconnect from the power supply. Remove the faulty component and replace only with genuine Record Power replacement parts. Any electrical components should only be replaced by a suitably qualified person. To replace a broken blade, please refer to the section of this manual entitled "Band saw Blade Set Up". Always remember to fully release the blade tension mechanism before attempting to fit a new blade. If you are in any doubt about using the machine following a failure or if you need to order replacement spare parts or blades, please contact customer services in your country.

Restarting

In the Event of a Blockage or if the Machine Stalls

If the bandsaw stalls due to the blade becoming trapped in the work piece, switch it off immediately by pressing the emergency stop button and wait for the machine to come to a complete stop before proceeding further.

If the blade is trapped within the work piece, it may be necessary to prize the work piece apart slightly using a suitable lever in order to free the blade. If it is not possible to free the blade using this method, then it may be necessary to cut the blade using suitable side cutters or tin snips. Replace the blade if necessary and ensure that it is correctly tracked and tensioned and that both doors of the bandsaw are fully closed and secured before attempting to re-start the machine.

To re-start the machine, press the green button marked 'I' on the switch.

In the Event of a Power Failure

The bandsaw is fitted with a no volt release (NVR) switch to protect the user against automatic starting of the machine when power is restored after a power failure.

In the event of a power failure, first locate and rectify the source of the failure. If the fault is within the power circuit of the workshop, there may be an underlying cause (circuit overload etc.) that should be investigated by a qualified electrician, before attempting to restore the power source.

If a cutting operation was taking place when the power supply was interrupted, then it may be necessary to free the blade from the work piece before attempting to re-start the machine.

Once the power is restored, the machine can be re-started by pressing the green button marked 'I' on the switch.

Blade Selection (TPI)

The selection of the best blade configuration (see the table below) is necessary for optimum cutting performance.

- Correct blade choice is primarily dependant on two factors: material thickness and material type.
- Greater TPI should be selected as material thickness decreases.
- However, if the TPI is too great, the tooth loading will be insufficient to enable penetration; and cutting. The teeth will also rapidly lose their sharpness.
- For thicker material a lower TPI should be used otherwise the gullet will not be sufficient to clear the waste and the blade will stall or burn the wood.
- In general a minimum of 3 teeth should be in contact with the wood at all times during cutting.

The accompanying blade selection chart (see the table below) gives guidance on the TPI that should give the best results when cutting a variety of material types and thickness. The table below provides recommendations on selecting the correct blade for a variety of commonly used materials. If in doubt about any aspects of blade selection contact Customer Services in your country.

The table provides a guide to selection only. Exact tooth configurations are not always available, nor are all blade configurations covered, but the principles remain the same.

For special applications, custom blades can be supplied please call Customer Services in your country and we can advise you accordingly on your specific needs.

12. Operation & Bandsawing Practice - Cont

Blade Selection (TPI) - Cont.

Having selected an appropriate blade for the particular thickness and type of material to be sawn, it is essential that the saw blade is allowed to cut freely by not applying too much pressure.

- The need for excessive pressure is likely to be a result of the incorrect blade selection or a worn blade and will result in inaccurate cutting and possibly blade breakage.

Blade Selection (Width)

- When cutting shapes, the width of the blade limits the minimum radius that can be cut.
 - If the blade is too wide for the cutting radius the blade will twist and possibly jam or break.
 - The smaller the radius the narrower the blade has to be.
- The diagram below provides guidance on the minimum radius to be cut with the most commonly used blade widths.

| Material | Material Thickness | | | |
|-------------|--------------------|---------|----------|---------|
| | <6 mm | 6-12 mm | 12-25 mm | >25mm |
| Perspex | 16 TPI | 14 TPI | - | - |
| Chipboard | - | 6 TPI | 3-6 TPI | 3-4 TPI |
| Fibre board | 16 TPI | 14 TPI | - | - |
| Hardboard | 10 TPI | - | - | - |
| Plywood | 10 TPI | 8 TPI | 6 TPI | 3-4 TPI |
| Strawboard | 14 TPI | 10 TPI | - | - |
| Cork | 14 TPI | 6 TPI | 3 TPI | 3-4 TPI |
| Leather | 14 TPI | - | - | - |
| Rubber | 10 TPI | 8 TPI | - | - |
| Wood -log | - | - | - | 3-4 TPI |
| Wood -soft | 6 TPI | 3-6 TPI | 3-4 TPI | 3-4 TPI |
| Wood -hard | 6 TPI | 3-6 TPI | 3-4 TPI | 3-4 TPI |
| Wood -wet | - | - | - | 3-4 TPI |

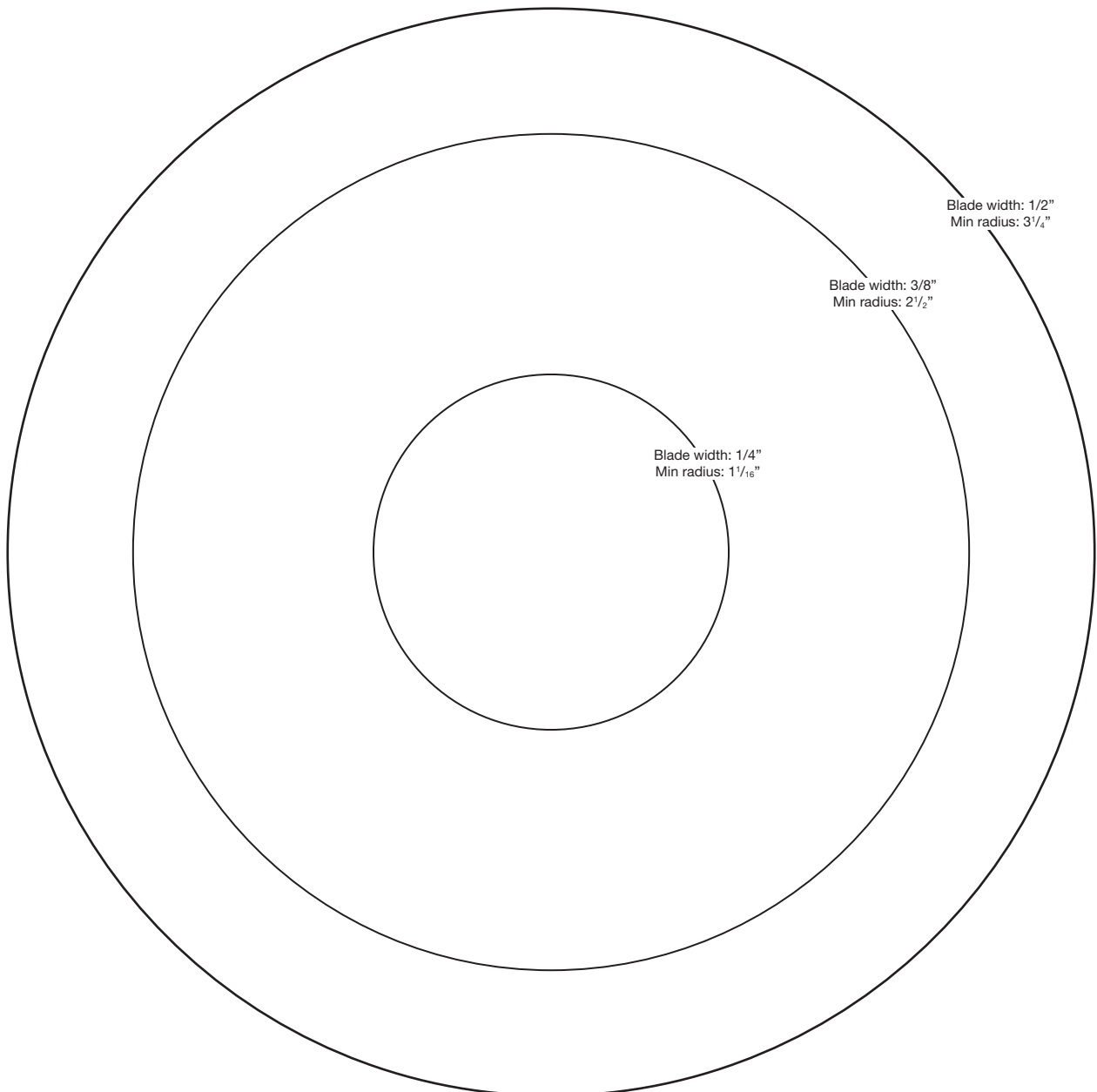

12. Operation & Bandsawing Practice - Cont

Blade Selection Summary

To see how TPI and width of the blade come together, use the table opposite for reference.

- Regularly examine the blade for excessive damage or cracking as a result of fatigue. If such damage is present replace the blade.
- It is important to use a sharp blade. Dull teeth result in increased feed pressure producing a poor quality finish and an inaccurate cut.



Note: As well as the blades listed, we can also supply bandsaw blades to almost any specification please call Record Power Customer Services in your country.

9.9 Record Power BS10 Blade Range

Record Power's high performance bandsaw blades are manufactured to the highest quality tolerances using a specialist premium high carbon steel strip.

The extensive quality control program which involves digital tooth profile checks, set analysis, straightness testing, hardness testing and micro structural analysis results in a blade that cuts straighter and has harder, longer lasting teeth. A premium British blade that can last up to ten times longer than other blades on the market. To order any of these blades please contact Record Power Customer Services in your country who will advise you of your nearest retailer or alternatively a mail order supplier.

BB67121406 1/4" x 6 TPI Bandsaw Blade

BB67123804 3/8" x 4 TPI Bandsaw Blade

BB67123806 1/2" x 4 TPI Bandsaw Blade

BB67121206 1/2" x 6 TPI Bandsaw Blade

BB6712-3PACK 1/4" x 6 TPI, 3/8" x 6 TPI and 5/8" x 6 TPI Bandsaw Blades

| | | Narrow Blade ← → Wide Blade | | |
|------------------------------------|--|---|--|--|
| | | Application TIGHT CONTOUR | Application MEDIUM CONTOUR | Application STRAIGHT CUT / LARGE CONTOUR |
| Coarse Blade ↑ Fine Blade ↓ | Material Thick / Soft Timber | Blade Spec width 1/4" teeth 4 TPI | Blade Spec widths 3/8" teeth 4 TPI | Blade Spec widths 1/2" teeth 4 TPI |
| | Material General Timber | Blade Spec width 1/4" teeth 4 - 6 TPI | Blade Spec widths 3/8" teeth 4 - 6 TPI | Blade Spec widths 1/2" teeth 4 - 6 TPI |
| | Material Thin / Hard Timber | Blade Spec width 1/4" teeth 6 TPI | Blade Spec widths 3/8" teeth 6 TPI | Blade Spec widths 1/2" teeth 6 TPI |

Custom Jigs & Work Support

A bandsaw is one of the most versatile machines in the workshop and with careful preparation many problems encountered on a job can be overcome. By making and using custom jigs repetitive and accurate work can easily be achieved, the following illustrations are some examples of typical jigs and supports used on a bandsaw.

Ex. 1. Supporting large workpieces with roller stands or take off tables.

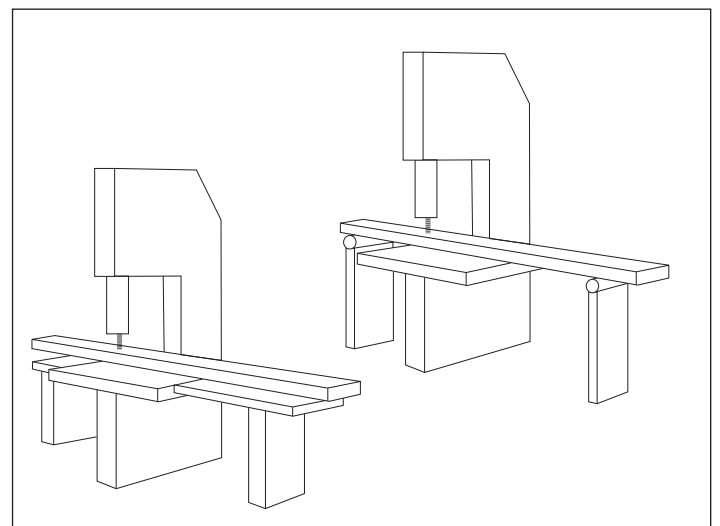

12. Operation & Bandsawing Practice - Cont

Ex. 2. Always support round pieces with a wedge or vee block. Take extreme care as there is a danger that if the work is not secured properly the blade will snatch the work piece, potentially causing it to spin or bounce back at you.

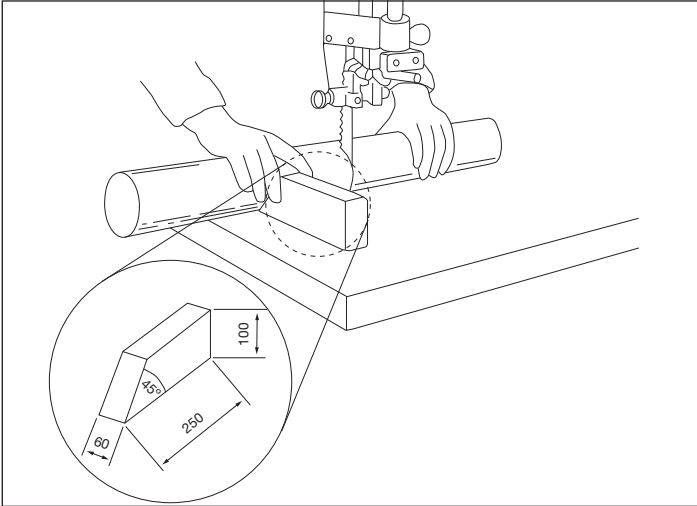

Ex. 5. Jig for accurate repetitive wedges.

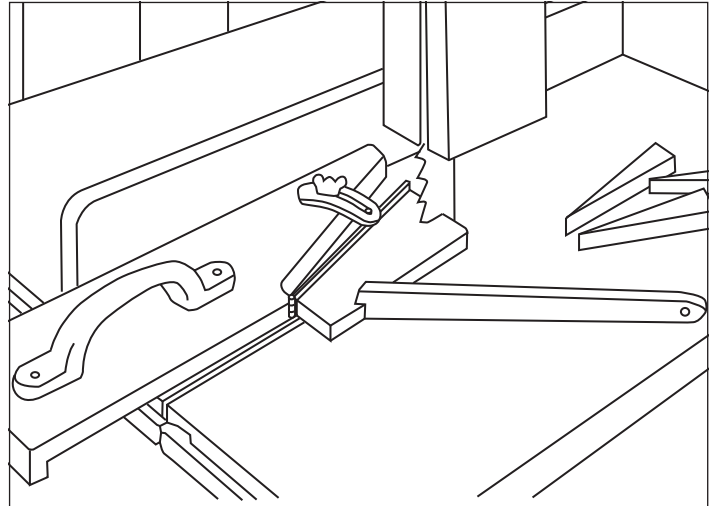

Ex. 3. Use a side pressure pad for accurate cutting of taller material.

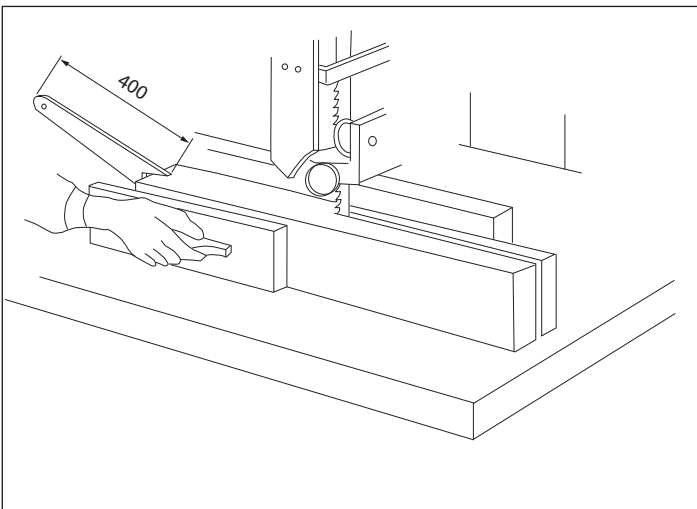

Ex. 6. By mounting a registration pin on a slide repetitive circles can easily be achieved.

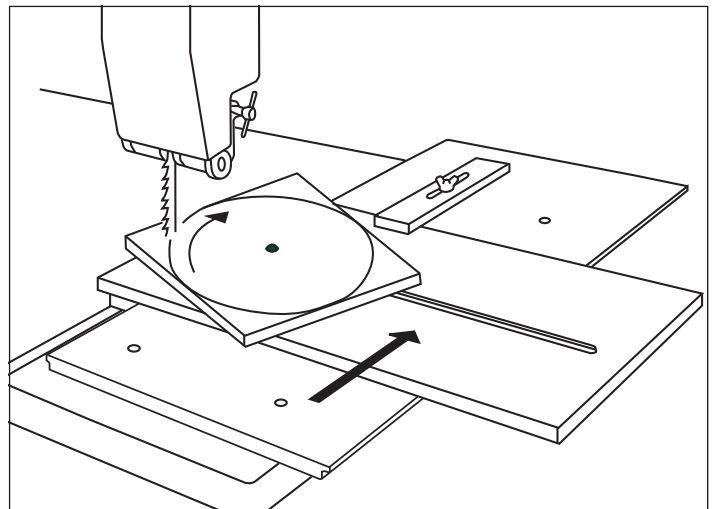

Ex. 4. Chamfered pieces can be cut squarely using an additional support jig on the opposite side of the work piece to the fence.

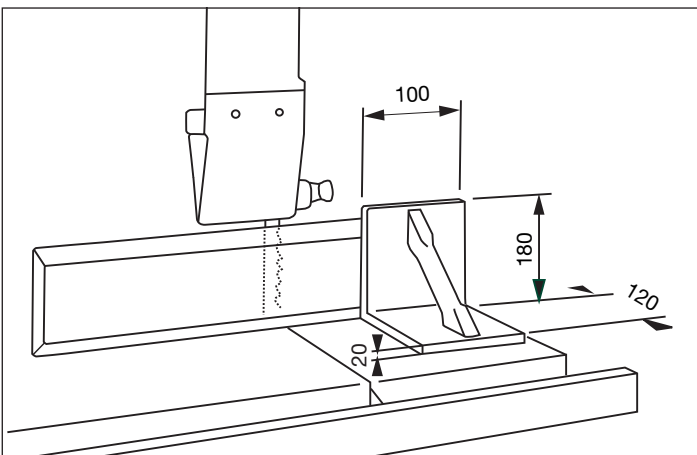

Ex. 7. Angle cutting jig for accurate repetitive compound angles.

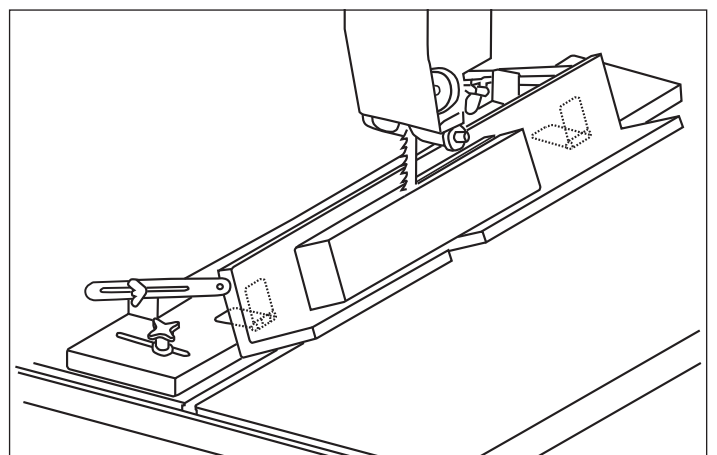

13. Dust Extraction

The Importance Of Dust Extraction

Before the machine is started, ensure that adequate dust extraction provisions have been installed. Dust extraction is extremely important not only for health and safety but also for the correct upkeep of the machine. Saw dust can cause the machine not to operate properly or even fail completely. By keeping the machine free of large amounts of waste the performance will be optimised.

If a large amounts of MDF or toxic woods are to be cut we recommend that there is a good ventilation system in place and that in addition to proper extraction a mask or respirator be worn as minimum protection.

Record Power Extractors

Record Power offer a range of high quality dust extractors, we offer both drum and bag type extractors which filter down 0.5 micron providing protection from harmful fine dusts. All Record Power dust extractors & chip collectors have 100 mm inlets and hoses.

DX1000 High Filtration Dust Extractor

Drum type extractor, 45 litre capacity, single 1 kW motor, suitable for intermittent use ie must be switched off for 20 minutes every hour.

0.5 micron filtration

RSDE1 High Filtration Dust Extractor

Drum type extractor, 45 litre capacity, single 1 kW motor, suitable for intermittent use ie must be switched off for 20 minutes every hour.

0.5 micron filtration

RSDE2 High Filtration Dust Extractor

Drum type extractor, 50 litre capacity, single 1 kW motor, suitable for intermittent use ie must be switched off for 20 minutes every hour.

0.5 micron filtration

RSDE/2A High Filtration Dust Extractor with Auto Switching

Drum type extractor, 50 litre capacity, single 1 kW motor, auto switching allows the machine to be turned on and off as machines and power tools are operated. Suitable for intermittent use ie must be switched off for 20 minutes every hour. Maximum auto switch capacity tools up to 1.1 kW.

0.5 micron filtration

DX4000 High Filtration Dust Extractor

Drum type extractor, 80 litre capacity, Twin 1 kW motor, suitable for heavy usage ie if one motor is switched off for 20 minutes then the other can be used thus enabling continuous usage. Or both motors can be used simultaneously giving maximum suction but in this mode the extractor must be switched off for 20 minutes every hour.

0.5 micron filtration

DX5000 High Filtration Dust Extractor

Bag type extractor, 200 litre capacity, Twin 1 kW motor, suitable for heavy usage ie if one motor is switched off for 20 minutes then the other can be used thus enabling continuous usage. Or both motors can be used simultaneously giving maximum suction but in this mode the extractor must be switched off for 20 minutes every hour.

0.5 micron filtration

CX2000 Compact Chip Extractor

Medium capacity chip collector, with a powerful 0.56 kW induction motor.

An extremely smooth running unit suitable for continuous usage. Very quiet impeller system extracts dust and chippings.

CX2600 Chip Collector

Large capacity chip collector, with a powerful 0.37 kW induction motor.

An extremely smooth running unit suitable for continuous usage. Very quiet impeller system extracts dust and chippings.

Suitable for chip collection or finer dust using the optional filter cartridge

CX3000 Chip Collector

Larger capacity chip collector, with a more powerful 0.75 kW induction motor and heavy duty construction. An extremely smooth running unit suitable for continuous usage. Very quiet impeller system extracts dust and chippings.

Suitable for chip collection or finer dust using the optional filter cartridge

Air Cleaners

It is strongly advised to also use an air cleaner to remove the fine airborne dust present in the workshop which cannot be removed using machine extraction. Record Power offer a range of air cleaners suitable for all home workshops. Please contact your preferred stockist or visit www.recordpower.info.

13. Dust Extraction - Cont

| | DX1000 | RSDE1 | RSDE2 | RSDE/2A | DX4000 | DX5000 | CX2000 | CX2600 | CX3000 |
|--|------------------|------------------|------------------|------------------|------------------|------------------|------------------|------------------|------------------|
| Bandsaws Circular saws Sanders Intermittent usage | ✓ Recommended | ✓ Recommended | ✓ Recommended | ✓ Recommended | ✓ Recommended | ✓ Recommended | | | |
| Bandsaws Circular saws Sanders Heavy usage | | | | | ✓ Recommended | ✓ Recommended | | | |
| Planer Thicknessers Spindle Moulders Universals Intermittent usage | ✓ Recommended | ✓ Recommended | | | ✓ Can be used | ✓ Recommended | ✓ Recommended | ✓ Recommended | ✓ Recommended |
| Planer Thicknessers Spindle Moulders Universals Heavy usage | | | | | ✓ Can be used | ✓ Recommended | | ✓ Recommended | ✓ Recommended |
| Dust Extraction System Intermittent usage | | | | | ✓ Can be used | ✓ Recommended | | | |

14. Maintenance

Replacing the Bandsaw Blade



CAUTION! Before carrying out any adjustments or maintenance ensure that the machine is isolated and disconnected from the electricity supply.



HAZARD! Take great care when unpacking the bandsaw blade as they are usually folded and can spring out very suddenly with great force.



TIP:

If the new blade being fitted is a different width to the one being removed, it is advisable to move back and slacken off all blade guides before fitting the new blade as this will make fitting easier. Whenever a different size blade is fitted the blade guides will always need re-setting.

1. Isolate the machine from the power supply.
2. Open the top and bottom bandwheel doors.
3. Remove the rip fence and rip fence rail (Fig 14.1).
4. Release the blade tension knob on the top of the machine, this will lower the top bandwheel and allow the blade to be removed.
5. Remove the bandsaw blade by feeding it through the slot in the table, upper blade guides & guard and slot in the spine of the machine taking care not to cut yourself, wear gloves if necessary (Fig 14.2).
6. Fit the new blade around the bandwheels ensuring the blade teeth are pointing downwards and towards you at the position where the blade passes through the table.
 - Ensuring that the blade is fully in place on the bandwheel re-apply tension using the tensioning knob.
 - Adjust the blade tension to suit the new blade.

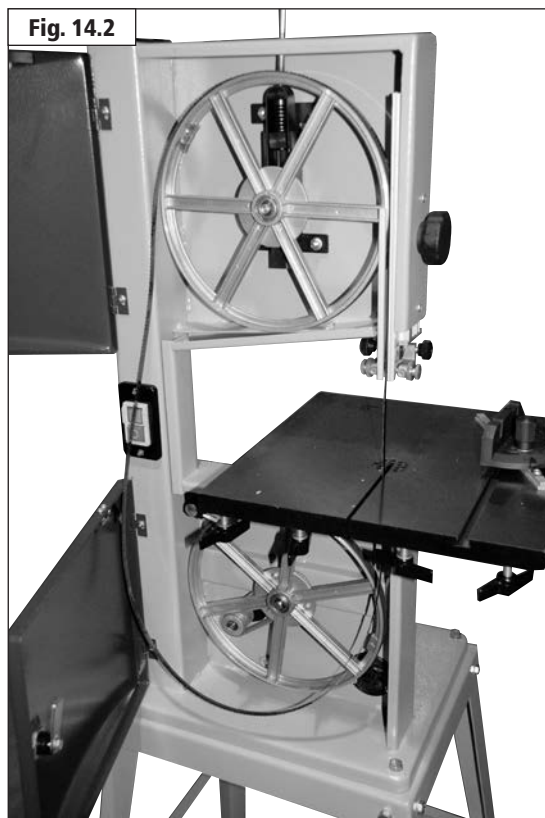
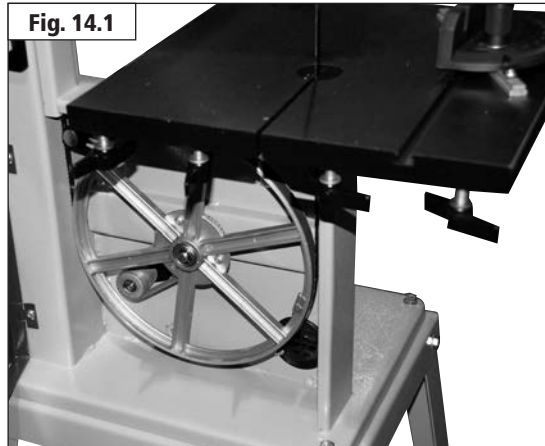

14. Maintenance - Cont.

7. Check the blade tracking on the newly fitted blade by turning the upper wheel by hand. To track the blade loosen the locking knob on the back of the machine and turn the tracking knob clockwise to move the blade back and anti clockwise to move the blade forward. The blade should run as close to the centre of the bandwheel as possible. When the blade is tracked correctly make a final check to ensure that the blade tension is adequate for the type of blade being used.
8. Re-set the blade guides.
9. Close and lock both the bandwheel doors, refit the fence rail and rip fence before re-connecting the power supply.

Replacing the Drive Belt



CAUTION! Before carrying out any adjustments or maintenance ensure that the machine is isolated and disconnected from the electricity supply.



Note:

Circlip pliers are required for this procedure.

1. To replace the drive belt slacken the tension on the belt by loosening the motor pivot screw on the back of the machine, lifting the motor and re-tightening the screw (Fig. 14.3, A).
2. Ease the drive belt (Fig. 14.4, B) off the motor pulley (Fig. 14.4, C).
3. Ensuring that there isn't a blade fitted now remove the lower bandwheel (Fig. 14.4, D) by releasing the circlip (Fig. 14.4, E) from the hub (Fig. 14.4, F).
4. Remove the old belt and fit the new one.
5. Once the drive belt is in place re-fit the lower bandwheel.
6. Now tension the drive belt by loosening the motor pivot screw and lowering the motor until adequate tension is applied. Re-tighten the motor pivot screw. The correct tension is achieved when there is approximately 6 mm of movement of the belt when reasonable pressure is applied by hand.

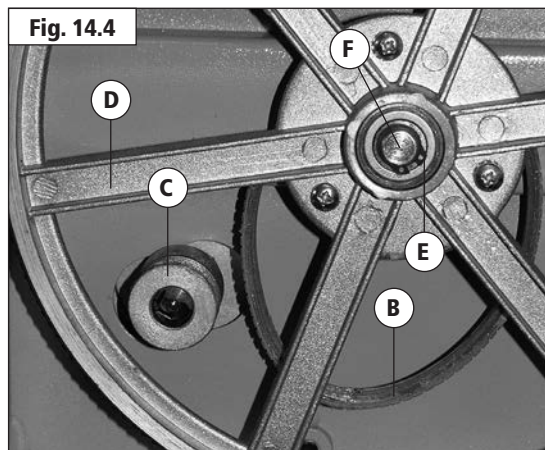
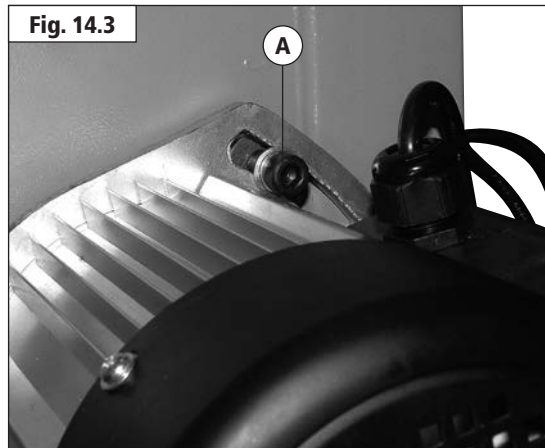

14. Maintenance - Cont.

The Blade Guide System

In general usage it is advisable to carefully apply silicone spray to the blade guides to ensure free movement of the rollers, do not use oil or grease for lubrication as this will attract dust and cause the rollers to jam. The blade guide system is a consumable item and depending on usage will wear and may need replacing.



CAUTION! It is advisable that the blade has been removed from the machine before replacing the blade guide components.

When replacing components on the upper guide assembly, loosen the guide carrier locking knob (Fig. 14.5, A) and remove the whole assembly.

When replacing components on the lower guide assembly, remove the pivot bolt (Fig 14.6, A) and then remove the whole assembly.

To change the side roller guides (Fig. 14.5), unscrew the locking ring (Fig. 14.5, A) and unscrew the roller support shaft (Fig. 14.5, B). As the support shaft is removed from the guide support casting, the guide roller will be extracted from the shaft. Replace the roller and re-assemble.

For full details on adjustment of the blade guides please see the bandsaw blade setup section of the manual.

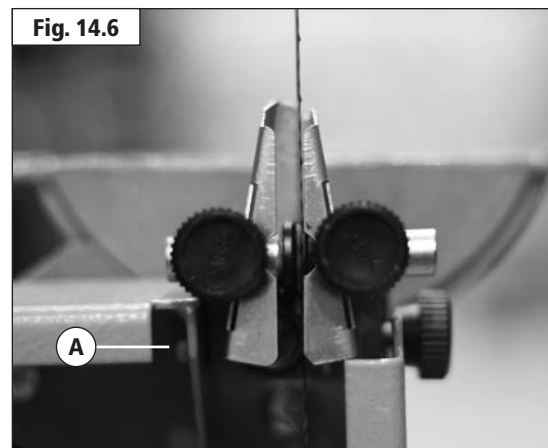
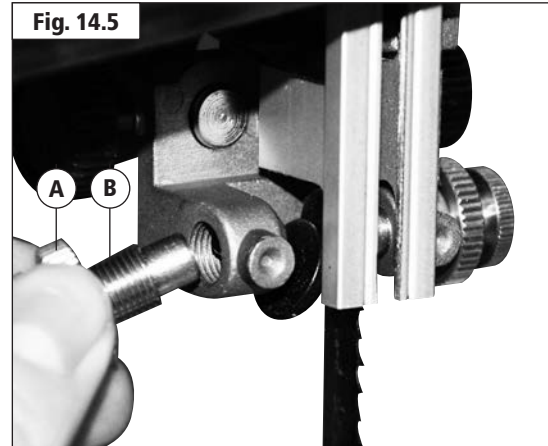

The Table Insert

The table insert on a bandsaw is a consumable item (Fig. 14.7 A) and will therefore need replacing periodically. This procedure should be carried out with the bandsaw blade removed. To replace the table insert simply push the old insert out from underneath the table and fit the new one into position.

The Bandwheel Tyres

The bandwheels on this machine have rubber tyres fitted to the outer rim of the wheel (Fig. 14.8, B) to protect the set of the blade when in use, also to provide drive and to stop the blade slipping. As part of your regular service schedule inspect the tyres for wear and damage and replace if necessary. Again this is a consumable part of the bandsaw and will need replacing periodically depending on usage. First remove the blade from the bandsaw, then remove the bandwheel. Gently ease the existing tyre from the rim taking care not to damage the bandwheel. To fit the new tyre it is a good idea to heat the tyre first in hot water, this softens the rubber up and makes it easier to stretch it over the bandwheel. The tyres before stretching are much smaller than the bandwheel and a good deal of stretching is required to make them fit. It is advisable to get help from a second person who can insert the wheel into the tyre while it is fully stretched.

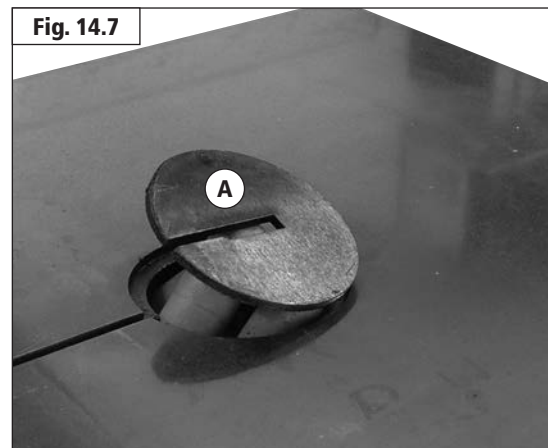

14. Maintenance - Cont.

The Bandwheel Bearings

The bandwheel bearings are sealed for life units which will need replacing periodically depending on usage.

To replace the bearings; first ensure that there is no blade fitted. Now remove the circlip from the hub and remove the bandwheel, you will notice that there are two separate bearings fitted in the hub pressed up against each other. Take a brass drift (or similar) and tap one of the bearings out, the second bearing should now be able to be pushed out.

When fitting the new bearings; position by hand in the wheel hub and tap in until the bearing seats against the ridge in the casting (Fig. 14.9).

Cleaning the Table

The table is made from cast iron and if cared for properly will provide smooth accurate performance. Obviously when machining wood a certain amount of resin will be deposited on the surface, to ensure optimum performance the table needs to be properly cleaned at regular intervals.

Firstly brush off all loose particles, then wipe clean with white spirit ensuring that any resin build up is dispersed and removed. Once the table has been thoroughly cleaned it can now be treated with CWA195 silicone spray or wax. If these guidelines are followed the timber will glide smoothly and accurately across the table.

The Bandwheel Brush

The purpose of this brush (Fig. 14.10, A) is to remove any excess sawdust and resin from the bandwheel and tyre. This brush will need adjusting periodically depending on usage. Before each use inspect the brush and make sure it is making sufficient contact with the bandwheel to remove sawdust from the tyre. The brush should be touching but not applying pressure to the wheel. If it is not then loosen the fixing nut (Fig. 14.11, B) and adjust accordingly so it makes contact with the wheel. When the brush cannot be adjusted any nearer the wheel due to the bristles being worn then it must be replaced. Periodically the brush may also become clogged up with resin (this is especially common when cutting a long run of soft wood) if this occurs this resin must be scraped off as performance of the brush will be reduced.

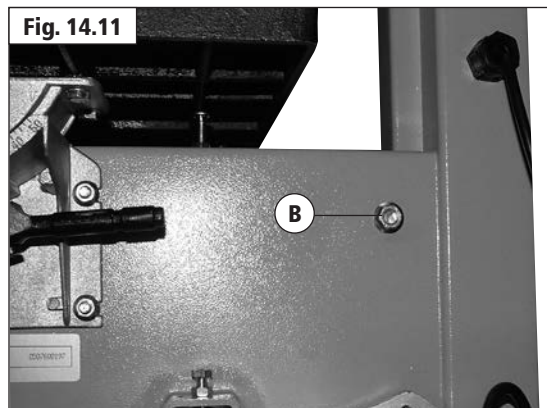
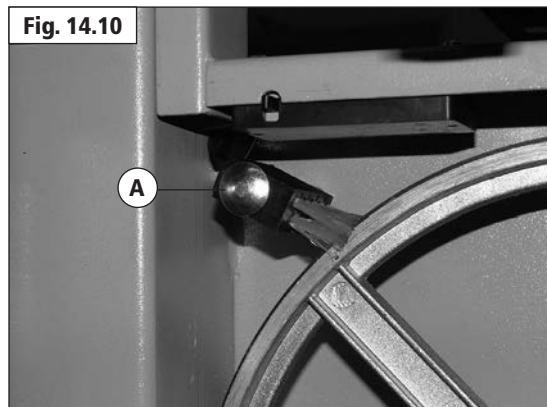
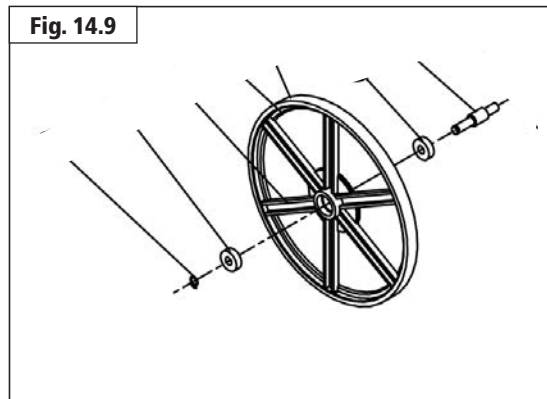
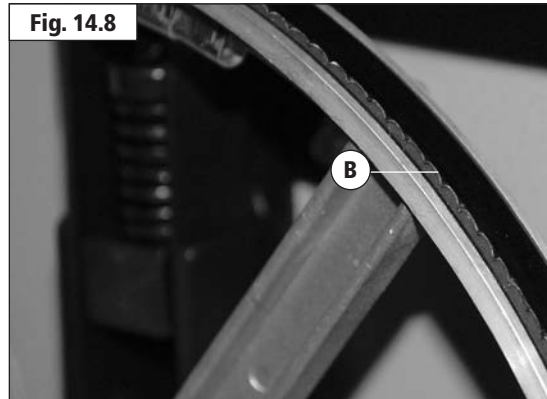

15. Parts List & Diagrams

| No. | Part Number | Part Name | Quantity | No. | Part Number | Part Name | Quantity |
|-----|--------------------|------------------------------|----------|-----|----------------------|--------------------------------------|----------|
| 1 | 31503031 | Slotted Insert Door Lock | 3 | 50 | GB96-85 6 | Washer | 1 |
| 2 | 31503022 | Washer | 3 | 51 | DJ315B03025 | Guide wheel | 3 |
| 3 | 31503032 | Housing | 3 | 52 | DJ315B03027 | Nut | 2 |
| 4 | 31503020 | Washer | 3 | 53 | DJ315B03025 | Roller | 3 |
| 5 | DJ250B04001 | Lower Door | 1 | 54 | DJ315B03023 | Shaft | 1 |
| 6 | 31503033 | Housing with Nut | 3 | 55 | GB/T276-94 625-2Z | Bearing | 3 |
| 7 | 31503030 | Clasp | 3 | 56 | 31504018 | Idler Wheel Shaft | 3 |
| 8 | GB862.2-87 6 | Ext.Lock Washer 6 | 3 | 57 | DJ250A04017 | Saw Blade Guard | 1 |
| 9 | GB5783-86 M6x10 | Hex Head Bolt M6 x 10 | 3 | 58 | DJ25002005 | Table Insert | 1 |
| 10 | DJ250B03001 | Upper Door | 1 | 59 | DJ250A02001 | Table | 1 |
| 11 | DJ250A05001 | Saw Blade | 1 | 60 | GB14-88 M6 x 30 | Cup Square Neck Bolt | 1 |
| 12 | GB894.1-86 10 | Retaining Ring | 2 | 61 | DJ25002006A | Guide Piece | 1 |
| 13 | GB/T276-94 6000-2Z | Ball Bearing | 4 | 62 | DJ250A02003 | Table Trunnion Upper | 1 |
| 14 | DJ250A03005 | Upper Wheel | 1 | 63 | DJ250A02004 | Indicator | 1 |
| 15 | DJ250A03005-1 | Balance Weights | fit | 64 | DJ250A02005 | Tension knob | 1 |
| 16 | DJ250A04009 | Band Saw Tyre | 2 | 65 | GB5783-86 M6 x 30 | Hex Head Bolt | 1 |
| 17 | DJ250A03004A | Upper Bearing Bolt | 1 | 66 | GB6170-86 M6 | Hex Nut | 5 |
| 18 | GB896-86 | "E" Rings | 2 | 67 | GB5783-86 M8 x 12 | Hex Head Bolt | 4 |
| 19 | DJ250A03007 | Pin Guide | 1 | 68 | DJ250A02014 | Rip Fence Carrier Extrusion | 1 |
| 20 | DJ250A03003B | Upper Seat Bearing Bolt | 1 | 69 | DT/SB052 | Handle | 1 |
| 21 | GB6177-86 M6 | Hex Head Flange Nut | 8 | 70 | DJ250D02005A | Cam wheel | 1 |
| 22 | DJ200030900 | Guide Plate Assembly | 1 | 71 | DJ315S02001-08 | Hinge axis | 1 |
| 23 | GB819-85 M4 x 12 | Cross Countersunk Head Screw | 2 | 72 | DJ250D03012 | Rip fence extrusion | 1 |
| 24 | 1000004481 | Magnetic Switch | 1 | 73 | RTS250G04010 | Cap | 2 |
| 25 | DJ25005004B | Switch Plate | 1 | 74 | DJ250D02003 | Hook | 1 |
| 26 | GB862.2-87 4 | Ext. Lock Washer | 2 | 75 | DJ31702113 | Magnifying glass | 1 |
| 27 | GB823-88 M4x6 | Cross Pan Head Screw | 2 | 76 | DJ250A02101 | Slide Board | 1 |
| 28 | DJ250A03010 | Blade Tensioner | 1 | 77 | DJ205A02003-5 | Plate | 1 |
| 29 | DJ250B01000 | Band Saw Frame | 1 | 78 | DJ315B03024 | Fastening Shaft | 1 |
| 30 | DJ250A05002 | End Cap | 1 | 79 | DJ250A03014A | Seat Guide Upper | 1 |
| 31 | DJ250A03008 | Blade Tracking Knob | 2 | 80 | GB846-85 ST4.2 x 13 | Cross Countersunk Head Tapping Screw | 2 |
| 32 | GB6172-86 M8 | Hex Head Thin Nut | 4 | 81 | DJ250A03022A | Housing Upper Guide | 1 |
| 33 | DJ250A03006 | Thread Bolt | 1 | 82 | DJ315B03026 | Shaft | 2 |
| 34 | GB97.1-85 6 | Washer | 6 | 83 | GB80-85 M6 x 6 | Int.Hd.Screw | 1 |
| 35 | GB5783-86 M6 x 12 | Hex Head Bolt | 9 | 84 | DJ250A03024 | Slide Board | 1 |
| 36 | GB5783-86 M8 x 45 | Hex Head Bolt | 1 | 85 | DJ250A03012 | Guide Lever | 1 |
| 37 | 31503007 | Wing knob | 1 | 86 | DJ315B03031-1 | Cover Board | 1 |
| 38 | GB97.1-85 8 | Washer | 10 | 87 | GB845-85 ST4.2 x 9.5 | Cross Pan Head Screw | 4 |
| 39 | TJ25004001-2 | Reed | 1 | 88 | DJ250A03018 | Rack | 1 |
| 40 | DJ250A03009 | Nut | 1 | 89 | DJ250A03013 | Guide Piece | 2 |
| 41 | DJ250A03011 | Shaft | 1 | 90 | DJ315B03016 | Adjust Knob | 1 |
| 42 | GB/T1792 A16 | Butterfly Spring | 18 | 91 | GB889-86 M8 | Hex Head Lock Nut | 1 |
| 43 | GB6177-86 M8 | Hex Head Flange Nut | 1 | 92 | GB818-85 M5 x 10 | Cross Pan Head Screw | 3 |
| 44 | DJ250A04014 | Spacer Bushing | 1 | 93 | DJ250A04005 | Lower Wheel | 1 |
| 45 | 31504015 | Brush Strip | 1 | 94 | DJ25004008 | Lower Pulley | 1 |
| 46 | GB14-88 M8x70 | Cup Square Neck Bolt | 1 | 95 | DJ25004010 | V-Ribbed Belts | 1 |
| 47 | DJ31703112 | Gear Shaft | 1 | 96 | GB1096-79 5 x 30 | Key | 1 |
| 48 | DJ31703113 | Gear | 1 | 97 | DJ25004004 | Motor Pulley | 1 |
| 49 | DJ250A02002 | Lower Blade Trunnion | 1 | | | | |

15. Parts List & Diagrams - Cont.

| No. | Part Number | Part Name | Quantity |
|-----|---------------------|----------------------|----------|
| 98 | GB5783-86 M6 x 16 | Hex Head Bolt | 4 |
| 99 | GB6171-86 M14 x 1.5 | Hex Nut | 1 |
| 100 | GB93-87 14 | Spring Washer | 1 |
| 101 | DJ250A04006 | Bearing Bolt lower | 1 |
| 102 | GB93-87 6 | Spring Washer | 4 |
| 103 | DJ25005003-1 | Motor Mounting Plate | 1 |
| 104 | YYL7114 | Motor | 1 |
| 105 | DJ250A05006 | Motor Cord | 1 |
| 106 | DJ250A05005 | Power Cord | 1 |
| 107 | GB6172-86 M6 | Hex Head Thin Nut | 2 |
| 108 | GB5783-86 M6 x 20 | Hex Head Bolt | 4 |
| 109 | 31505010A | Cable gland | 2 |
| 110 | GB70.1 M5 x 10 | Screw | 2 |

15. Parts list and Diagrams - Cont.

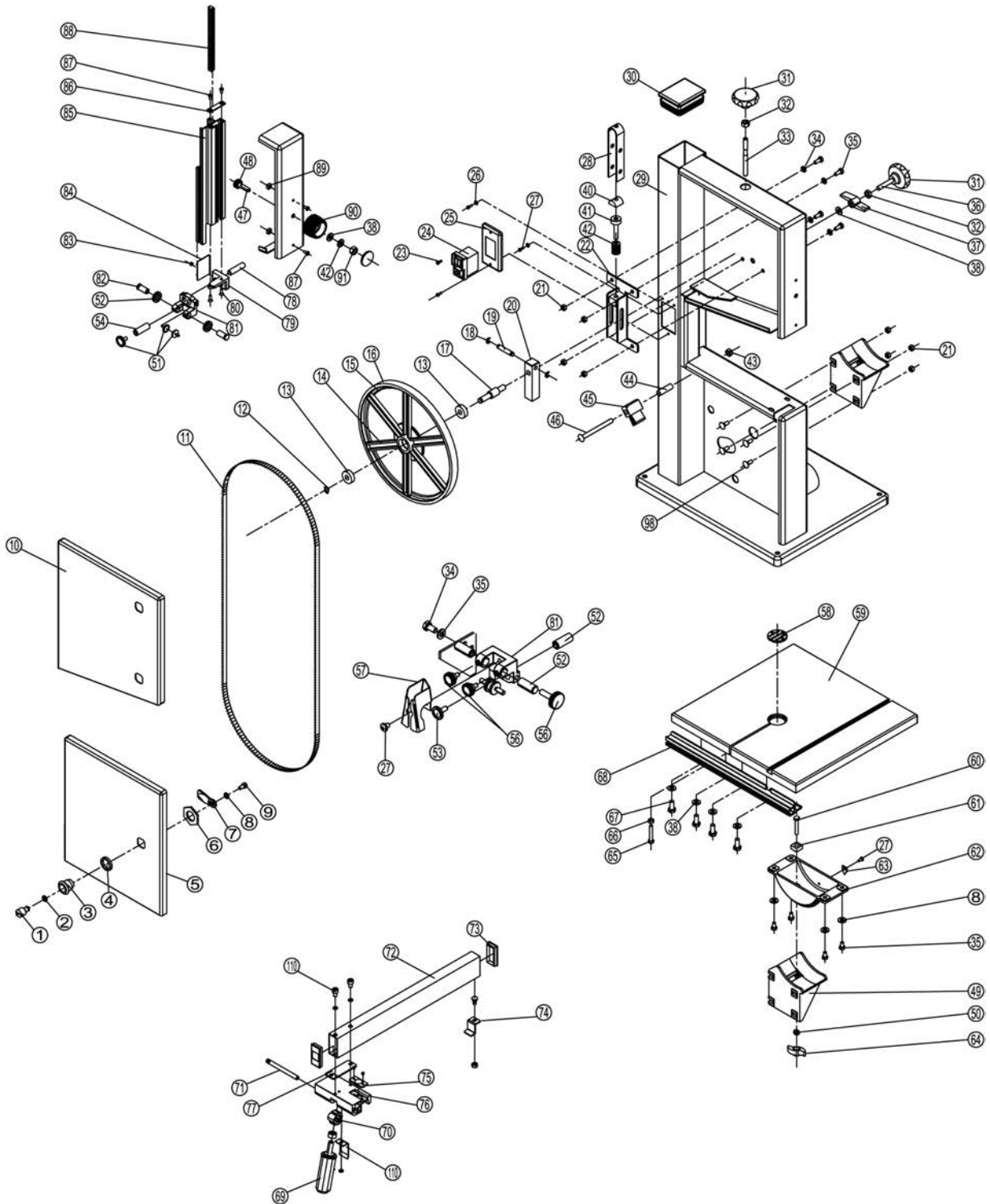

15. Parts list and Diagrams - Cont.

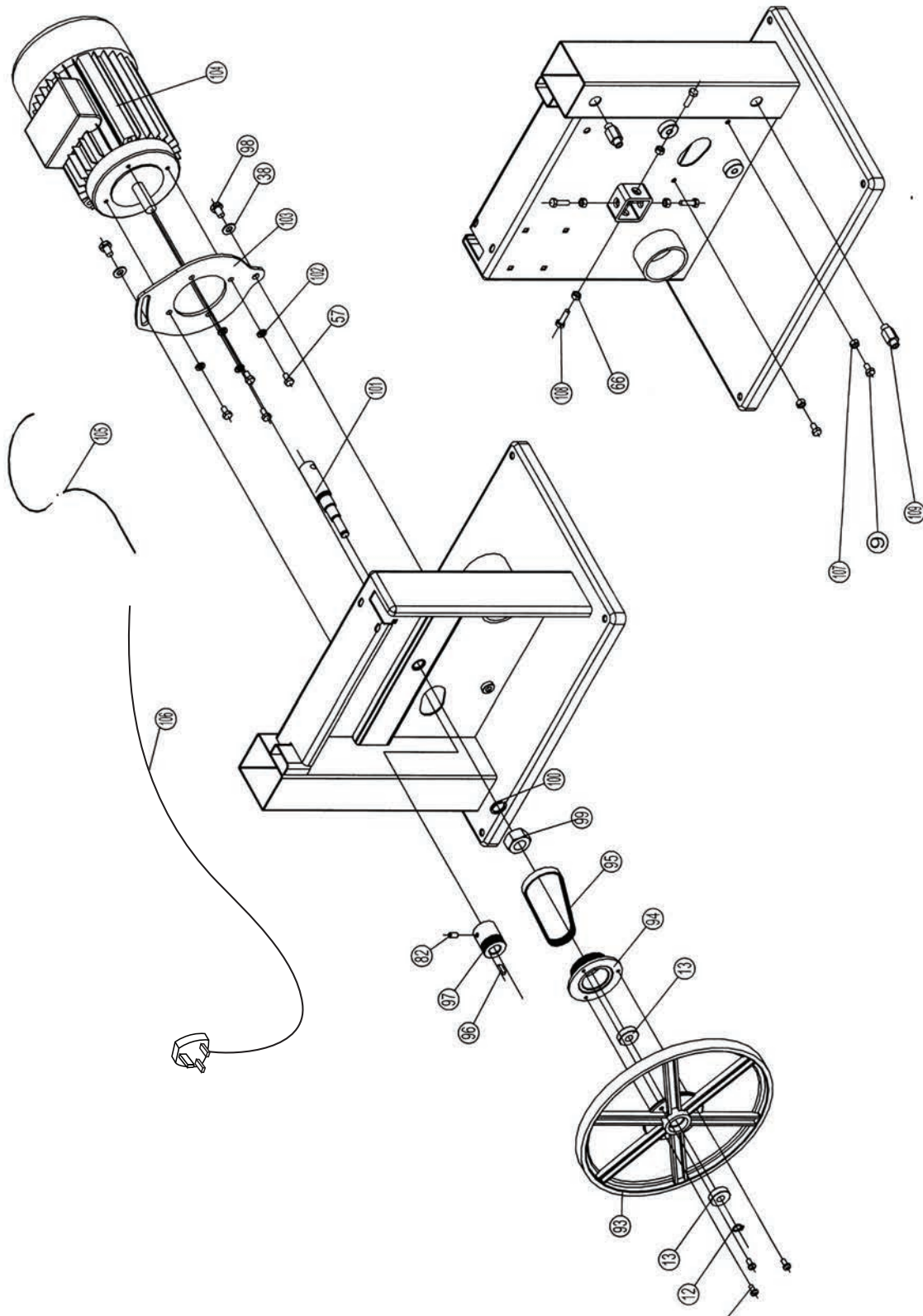

EU Declaration of Conformity

Cert No: EU / BS10 / 1

Record Power Limited,

Centenary House, 11 Midland Way, Barlborough Links,
Chesterfield, Derbyshire S43 4XA

declares that the machinery described:-

1. Type: **Bandsaw**
2. Model No: **BS10**
3. Serial No

Conforms with the following directives:-

| | |
|--|--|
| MACHINERY DIRECTIVE | 2006/42/EC |
| LOW VOLTAGE DIRECTIVE | 2006/95/EC |
| ELECTROMAGNETIC COMPATIBILITY DIRECTIVE | 2004/108/EC EN 55014-1:2006 EN 61000-3-2:2006 EN 61000-3-3:1995+A1+A2 EN 55014-2:1997+A1 |

and conforms to the machinery example for which the
EC Type-Examination Certificate No. **AE 5014 73510001, BM50172180-0001**
has been issued by **TÜV Rheinland LGA Product GmbH**,
at: Tillystrasse 2, 90431 Nürnberg

and complies with the relevant essential health and safety requirements.



Signed.....Dated: **01/02/2014**

Andrew Greensted
Managing Director



Over
100
 years
 Experience • Knowledge
 Support • Expertise



RECORD POWER
 ESTABLISHED 1909®

Woodworking Machinery & Accessories

United Kingdom

Record Power Ltd
 Centenary House, 11 Midland Way
 Barlborough Links, Chesterfield
 Derbyshire S43 4XA
 Tel: 01246 571 020
 Fax: 01246 571 030
www.recordpower.co.uk

Eire

Record Power Ltd
 Centenary House, 11 Midland Way
 Barlborough Links, Chesterfield
 Derbyshire S43 4XA
 Tel: 01246 571 020
 Fax: 01246 571 030
www.recordpower.co.uk

Australia

Tools 4 Industry
 Po Box 3844
 Parramatta 2124
 Tel: 1300 124 422
 Fax: 1800 262 725
www.recordpower.com.au

New Zealand

Tools 4 Industry
 Po Box 276079
 Manukau City 2241
 Tel: 0800 142 326
 Fax: 09 2717 237
www.recordpower.co.nz